



**PHBB Valves Private Limited**

(Formerly PJV Valves Pvt Ltd)

**Pune**



# Company History

- Founded by Two Engineers with extensive experience in Valve Industry
- Commenced manufacturing of BALL Valves in 2009 in Pune, India
- Products - Floating & Trunnion Ball valves including Metal seated, Fully Welded, Top Entry, Three way, Jacketed, Segmented & Double Offset Butterfly Valves
- Wide variety in designs, construction, materials & testing
- Specialize in supply to Projects with complex specifications & documentation
- Conversant with all the latest specifications for Ball valves prevailing in most of the industries including Oil & Gas, Petrochemicals, Specialty Chemicals, Power & Mining.

# Ball Valves

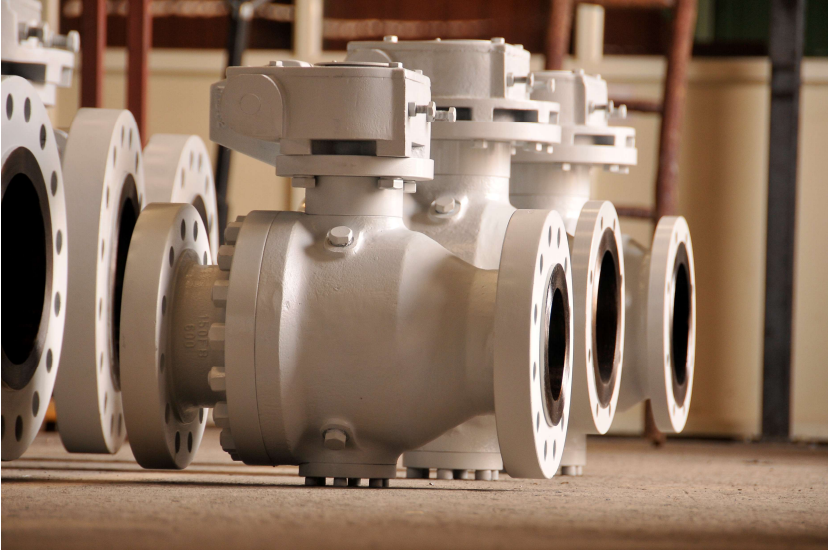



# Certifications



**American  
Petroleum  
Institute**



2018-151 | Digital

## Certificate of Authority to use the Official API Monogram

License Number: 6D-0101

ORIGINAL

The American Petroleum Institute hereby grants to

**PHBB VALVES PRIVATE LIMITED**  
Plot No 238-239 Sector 10, PCNTDA Bhosari  
Pune, Maharashtra  
India

the right to use the Official API Monogram® on manufactured products under the conditions in the official publications of the American Petroleum Institute entitled API Spec Q1® and **API-6D** and in accordance with the provisions of the License Agreement.

In all cases where the Official API Monogram is applied, the API Monogram shall be used in conjunction with this certificate number: **6D-0101**

The American Petroleum Institute reserves the right to revoke this authorization to use the Official API Monogram for any reason satisfactory to the Board of Directors of the American Petroleum Institute.

The scope of this license includes the following: Ball Valves

QMS Exclusions: No Exclusions Identified as Applicable

Effective Date: **JANUARY 12, 2021**  
Expiration Date: **JANUARY 12, 2024**

To verify the authenticity of this license, go to [www.api.org/compositelist](http://www.api.org/compositelist).

Vice President of Global Industry Services



REGISTRATION NO. Q1-2568



## Certificate of Registration

The American Petroleum Institute certifies that the quality management system of

**PHBB VALVES PRIVATE LIMITED**  
Plot No 238-239 Sector 10, PCNTDA Bhosari  
Pune, Maharashtra  
India

has been assessed by the American Petroleum Institute and found to be in conformance with the following:

## API Specification Q1

The scope of this registration and the approved quality management system applies to the:

**Design and Manufacture of Industrial and Pipeline Valves,  
Valve Components, Valve Automation and Accessories**

API approves the organization's justification for excluding:

**No Exclusions Identified as Applicable**

Effective Date: **JANUARY 12, 2021**  
Expiration Date: **JANUARY 12, 2024**  
Registered Since: **JANUARY 12, 2015**

Vice President of Global Industry Services

This certificate is valid for the period specified herein. The registered organization must continually meet all requirements of API Spec Q1, Specification for Quality Programs for the Petroleum, Petrochemical and Natural Gas Industry, and the requirements of the Registration Agreement. Registration is maintained and regularly monitored through annual full system audits. This certificate has been issued from API offices located at 200 Massachusetts Avenue, NW Suite 1100, Washington, DC 20001-5571, U.S.A. It is the property of API, and must be returned upon request. To verify the authenticity of this certificate, go to [www.api.org/compositelist](http://www.api.org/compositelist).

2020-160 | 06.20 | Digital





# Certificate

## Quality-Assurance System

acc. to Directive 2014/68/EU

Certificate no.: 01 202 IND/Q-20 0004

Name and address of the manufacturer:

PHBB Valves Private Limited.  
Plot No. 238-239, Sector 10,  
PCNTDA, Bhosari Pune-411 026  
India

Herewith we certify that the above -mentioned manufacturer operates a quality system according to the European Directive 2014/68/EU. The manufacturer has the permission to affix the following CE marking to pressure equipment described and manufactured in accordance to the scope covered by this Quality-Assurance System:

**CE 0035**

Tested acc. to  
Directive 2014/68/EU:

**QA-System (Module H)**  
(the QA-Modules E1, E, D1, D are covered by Module H)

Audit report no.:

IND/Q-20 0004

Area of validity:

Design and Manufacturing of Ball Valves & Butterfly Valves,  
see annex to certificate

Manufacturing plant:

PHBB Valves Private Limited.  
Plot No. 238-239, Sector 10,  
PCNTDA, Bhosari Pune-411 026  
India

Valid until:

March 3, 2023

Cologne, March 4, 2020

Dipl.-Ing. (FH) Roman Alexander Meyers



The manufacturer  
may use the mark:



Revision 1.0 Jul 24, 2020  
Surveillance Audit Due  
Aug 01, 2023



# Certificate / Certificat Zertifikat / 合格証



PHB 2004152 C001

*exida* hereby confirms that the:

**Floating Ball Valve**  
**PHBB Valves Pvt Ltd**  
**Pune - India**

Has been assessed per the relevant requirements of:

**IEC 61508 : 2010 Parts 1-7**

and meets requirements providing a level of integrity to:

**Systematic Capability: SC 3 (SIL 3 Capable)**  
**Random Capability: Type A, Route 2<sub>H</sub> Device**

**PFH/PFD<sub>avg</sub> and Architecture Constraints  
must be verified for each application**

### Safety Function:

The Ball Valve will move to the designed safe position per the actuator design within the specified safety time.

### Application Restrictions:

The unit must be properly designed into a Safety Instrumented Function per the Safety Manual requirements.



Evaluating Assessor

Certifying Assessor

# MANAGEMENT SYSTEM CERTIFICATE

Certificate No:  
10000372948-MSC-RvA-IND

Initial certification date:  
02 August 2017  
(by different Certification Body)

Valid:  
02 August 2020 - 01 August 2023

This is to certify that the management system of

## PHBB Valves Pvt. Ltd.

Plot No. 238 & 239, Sector No.10, PCNTDA, Bhosari, MIDC, Pune - 411 026,  
Maharashtra, India

has been found to conform to the Occupational Health and Safety Management  
System standard:

**ISO 45001:2018**

This certificate is valid for the following scope:

**Design manufacture and supply of industrial valves, Valve components,  
Valve automation and accessories**

Place and date:  
Barendrecht, 10 July 2020



For the issuing office:  
DNV GL - Business Assurance  
Zwolsseweg 1, 2994 LB Barendrecht,  
Netherlands

Erie Koek  
Management Representative



# MANAGEMENT SYSTEM CERTIFICATE

Certificate No:  
10000372947-MSC-RvA-IND

Initial certification date:  
02 August 2017

Valid:  
02 August 2020 - 01 August 2023

This is to certify that the management system of

## PHBB Valves Pvt. Ltd.

Plot No. 238 & 239, Sector No.10, PCNTDA, Bhosari, MIDC, Pune - 411 026,  
Maharashtra, India

has been found to conform to the Environmental Management System standard:  
**ISO 14001:2015**

This certificate is valid for the following scope:

**Design manufacture and supply of industrial valves, valve components,  
valve automation and accessories**

Place and date:  
Chennai, 03 July 2020



The RvA is a signatory to the IAF MLA



For the issuing office:  
DNV GL - Business Assurance  
ROMA, No. 10, GST Road, Alandur,  
Chennai - PIN - 600 016, India

Sivadasan Madiyath  
Management Representative



# Ball Valves – Floating & Trunnion

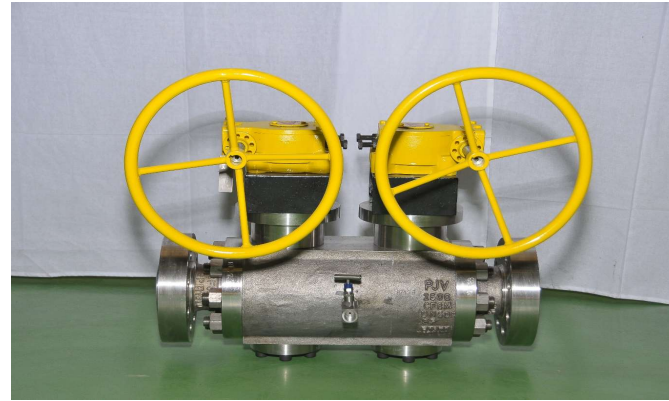

**FIRE TESTED - AS PER API  
607/API6FA  
FUGITIVE EMISSION TESTED AS  
PER - ISO 15848  
CANADIAN REGISTRATION (CRN)  
SIL CERTIFIED TO IEC 61508**



# Floating Ball Valve – Full Bore & Reduced Bore

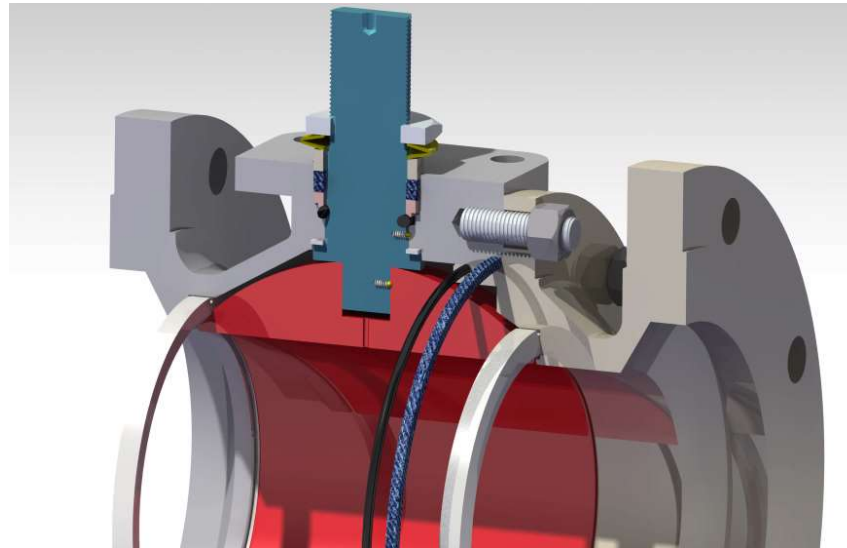
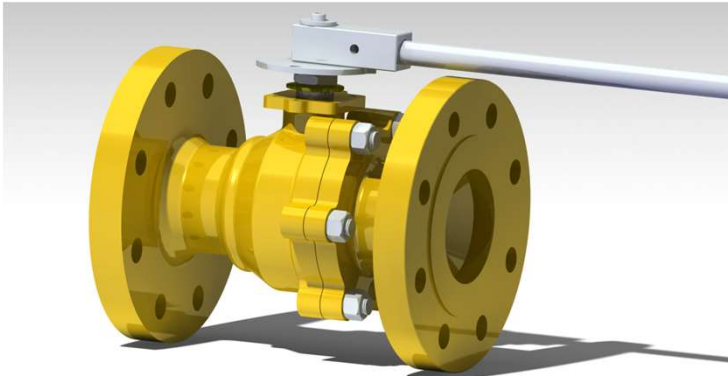

## Size Range

Size : DN8 to DN350

Rating : Class 150 to 2500

## Features :

- ❖ Blow Out Proof Stem
- ❖ Tamper Proof Anti-Static Device
- ❖ Optional Open & Close Position Locking
- ❖ Wide Stem and Body seal options
- ❖ Valves are Tested for Fugitive Emissions
- ❖ Fire Safe Design
- ❖ Options of Double Body Seals & Triple Sealing Stem
- ❖ Wide Range of Seat & Seal Materials
- ❖ Construction Available in Single, Two and Three piece



# Trunnion Ball Valve – Full Bore & Reduced Bore

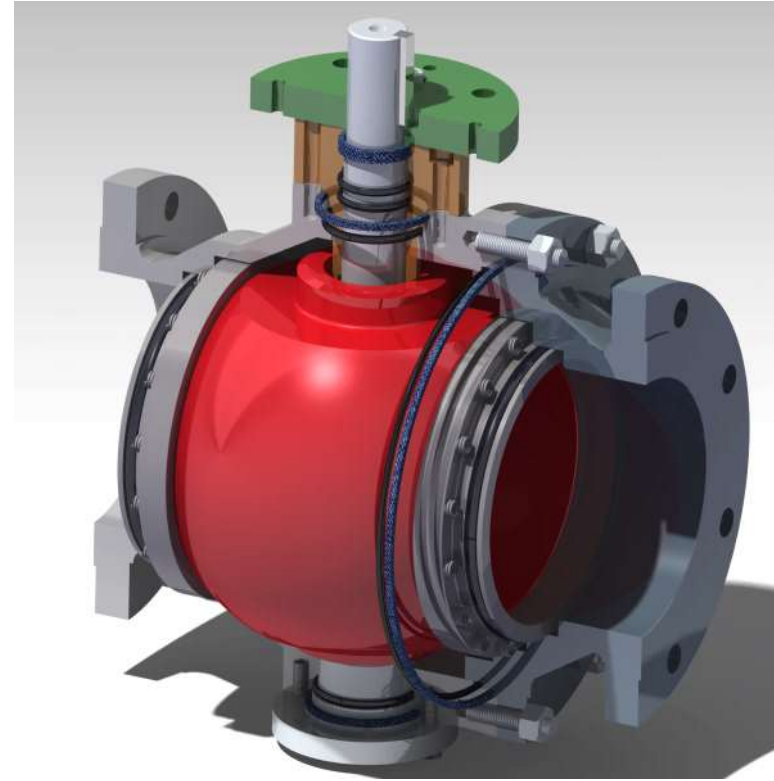
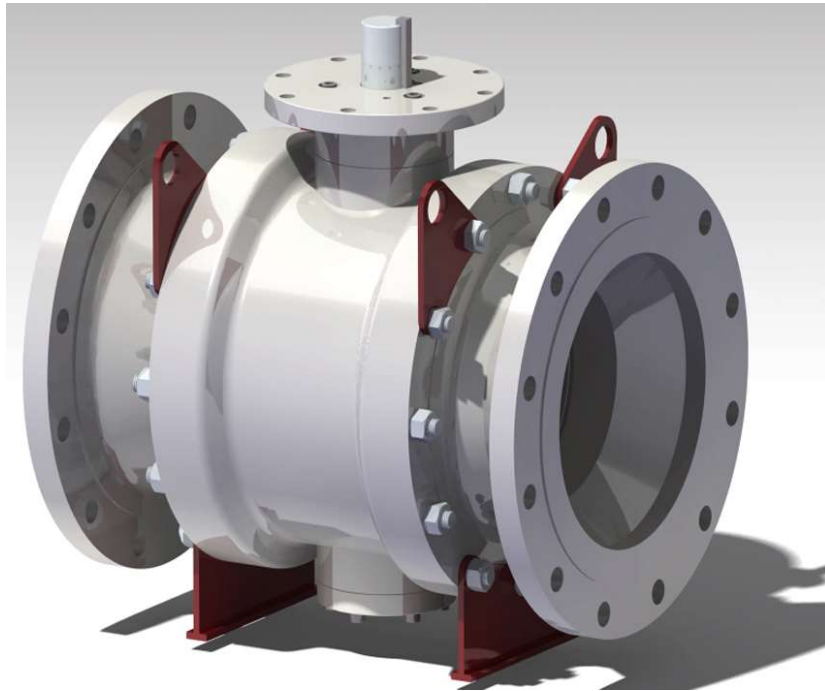

## Size Range

Size : DN40 to DN600

Rating : Class 150 to 2500

## Features :

- ❖ Bolted Body, Side Entry Construction
- ❖ Double Block & Bleed, Self relieving seats
- ❖ Option of Single piston & Double piston seats
- ❖ Fire Safe Design
- ❖ Tamper Proof Anti-Static Device
- ❖ Double Seal Body Joint & Multiple Stem sealing
- ❖ Wide Stem & Body Seal options
- ❖ Wide Range of Seat & Seal Materials
- ❖ Provision for optional emergency stem & Seat Sealant injection
- ❖ Optional Open & Close Position Locking
- ❖ Valves are Type Tested for Fugitive Emission
- ❖ Blowout proof Stem assists replacement of stem seal under pressure



# Metal Seated Ball Valves – Floating & Trunnion

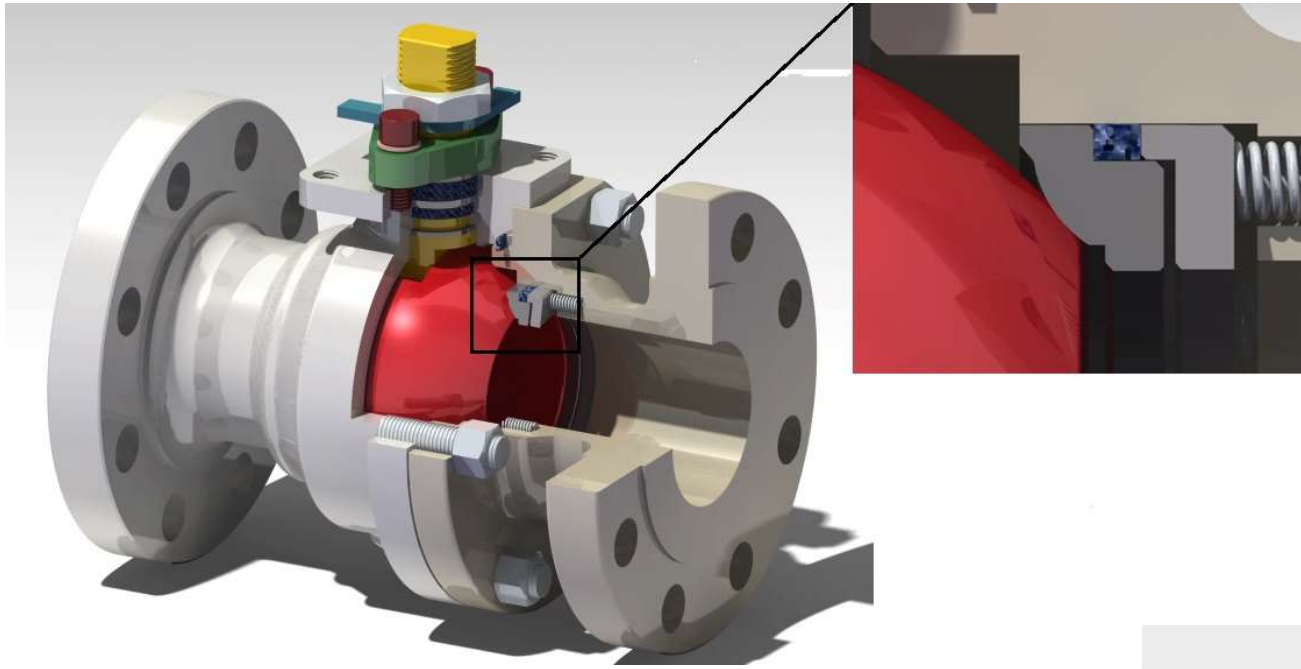

## Size Range for Metal seated Trunnion Ball Valve

Size : DN50 to DN400

Rating : Class 150 to 2500

## Size Range for Metal seated Floating Ball Valve

Size : DN10 to DN100

Rating : Class 150 to 2500

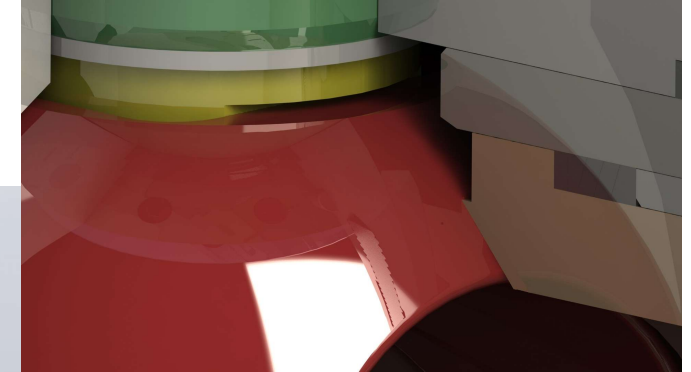
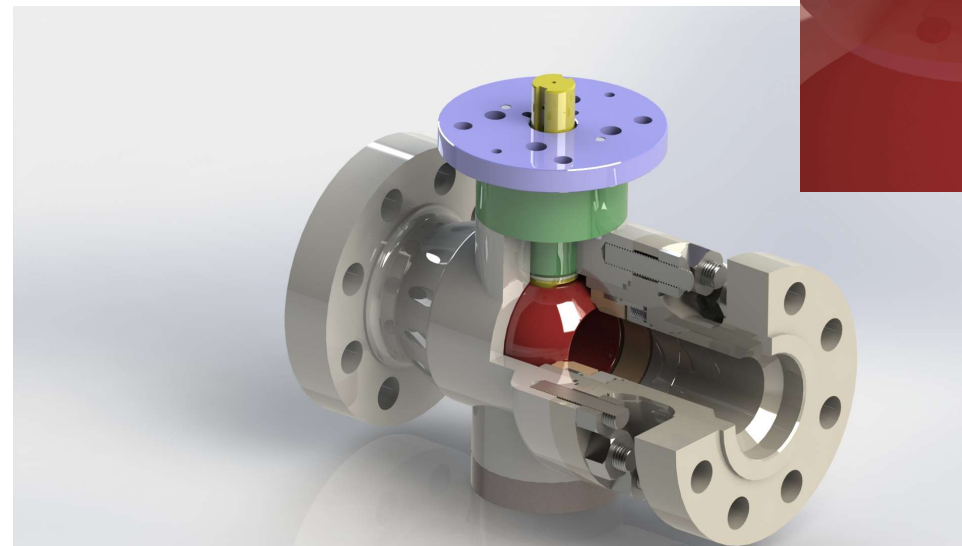



# Segmented Ball Valves



## Size Range

Size : DN25 to DN300

Rating : Class 150 & 300

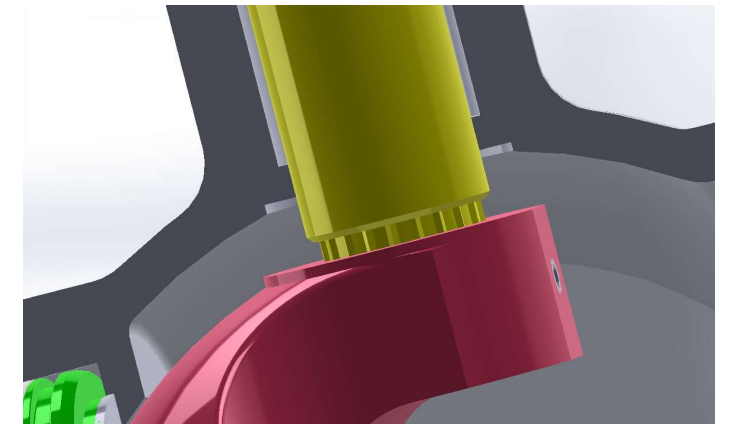
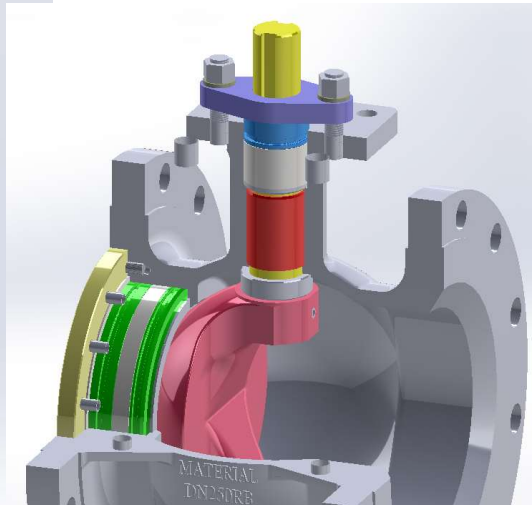

## Features & Benefits :

- ❖ Single piece body design offers greater rigidity against fluctuating pipe loads
- ❖ Design available in Weld ends & Flanged Ends
- ❖ Designed and characterized Segment for On-off and control applications
- ❖ Optional Hard coating on ball
- ❖ Disc locator design for ball centering

# V-Notch Ball Valve

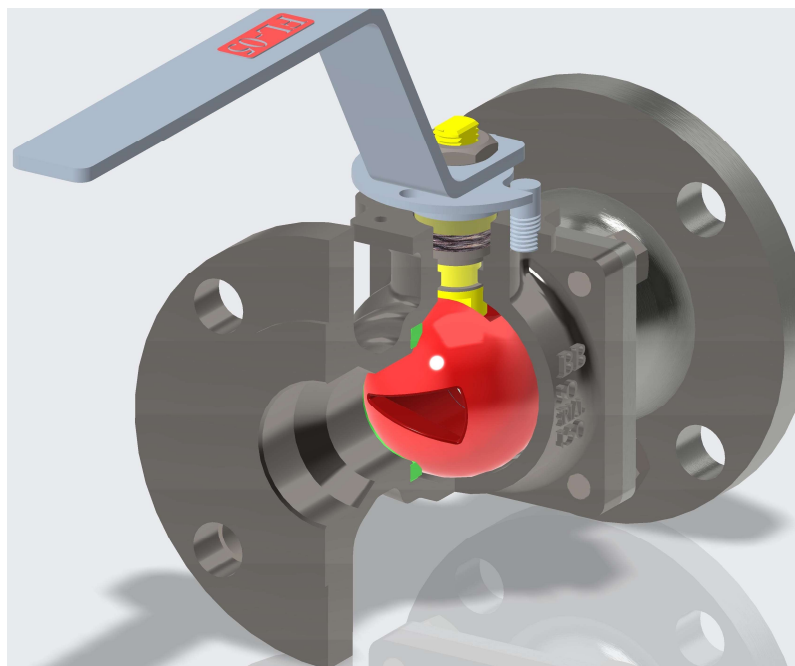

## Size Range

Size : DN20 to DN200

Rating : Class 150 to 600

## Features :

- ❖ Blow Out Proof Stem
- ❖ Tamper Proof Anti-Static Device
- ❖ Optional Open & Close Position Locking
- ❖ Excellent flow control and rangeability
- ❖ Fire Safe Design
- ❖ Double Seal Body Joint & Live loaded Stem Packing
- ❖ Wide Range of Seat & Seal Materials

V-NOTCH ANGLE 90°

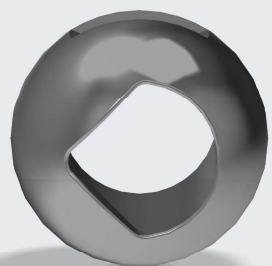

V-NOTCH ANGLE 60°

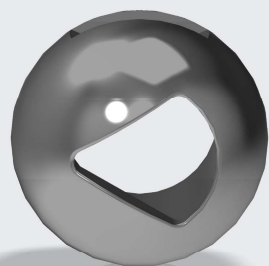

V-NOTCH ANGLE 30°

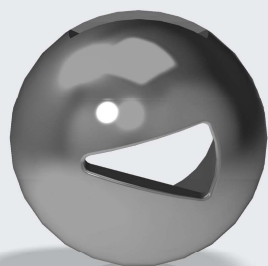

V-NOTCH ANGLE 15°

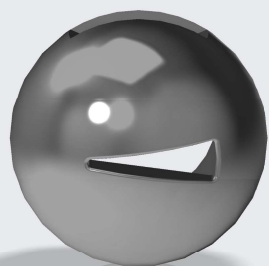



# Tank Bottom Ball Valves



## Size Range

Size : DN25 to DN200

Rating : Class 150 to 600

Ends : Flanged, Wafer type



## Features :

- ❖ Minimum dead leg between ball sphere & tank internal surface
- ❖ Top mounting flange compliant with ISO 5211 for easy mounting of actuator
- ❖ Wide Range of Seat & Seal Materials
- ❖ Optional purge ports ensure complete flush of the valve cavity
- ❖ Optional Open & Close Position Locking
- ❖ Optional Stem jacket
- ❖ Streamline flow ensures full drainage

# Special Ball Valves

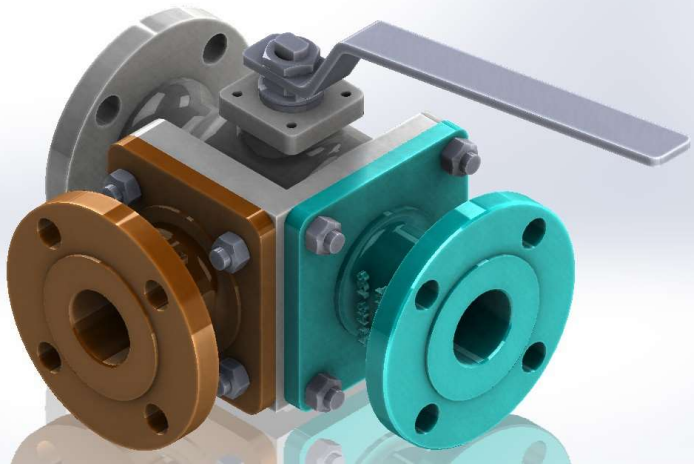

## Multi-Port Ball Valves

Size : DN25 to DN300  
Rating : Class 150 to 600

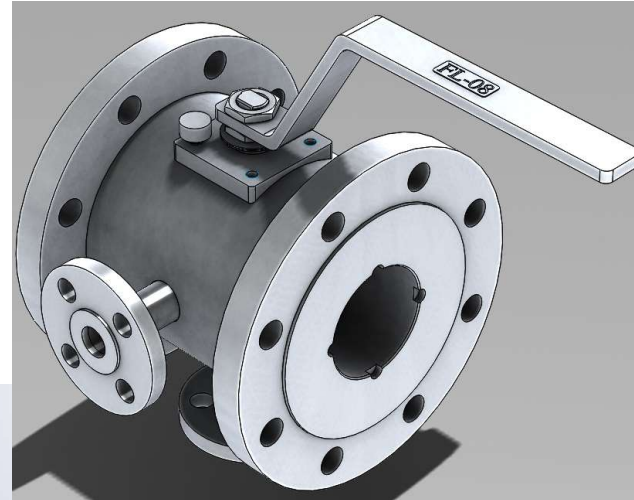

## Jacketed Ball Valves

Size : DN15 to DN300  
Rating : Class 150 to 1500  
Jacket type : Full or Partial Jacketed  
Drain : Flanged/NPT/BSP

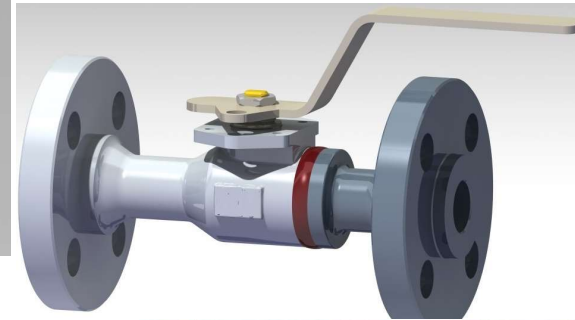

## Fully Welded Ball Valves

Size : DN25 to DN600  
Rating : Class 150 to 1500  
Type : Floating & Trunnion

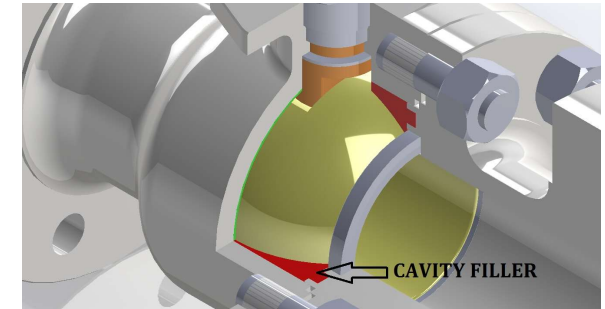

## Cavity Filled Ball Valves

Size : DN15 to DN25  
Rating : Class 150 to 600  
Material : PTFE, TFM





# High Performance Double Offset Butterfly Valves



## Size Range

Size : DN50 to DN750

Rating : Class 150 to 600

Ends : Flanged, Wafer, Lugged



# High Performance - Triple Offset Butterfly Valves

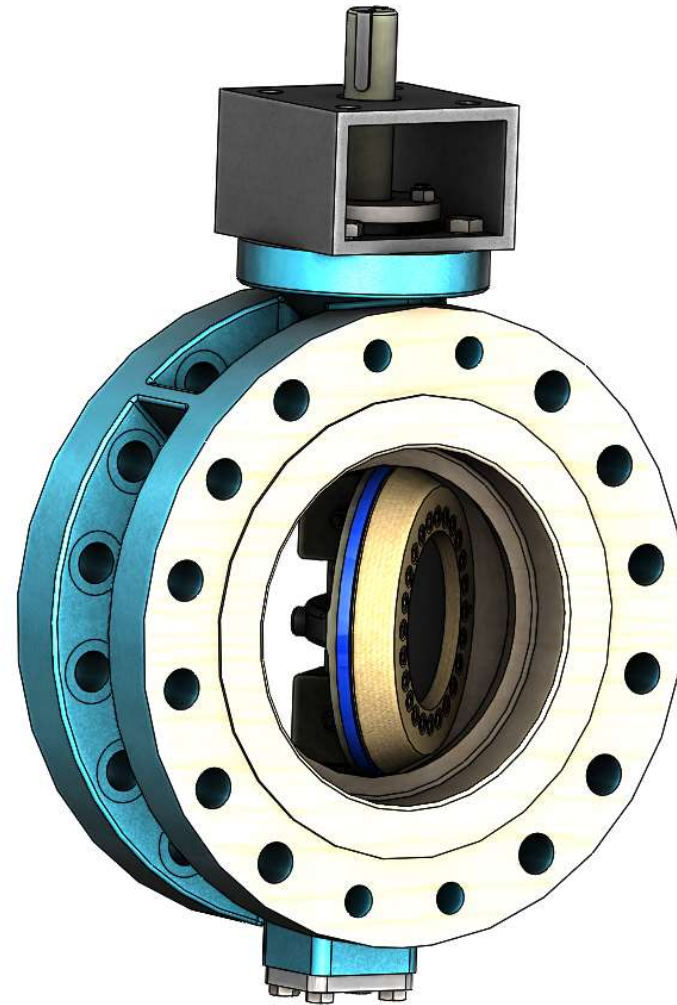
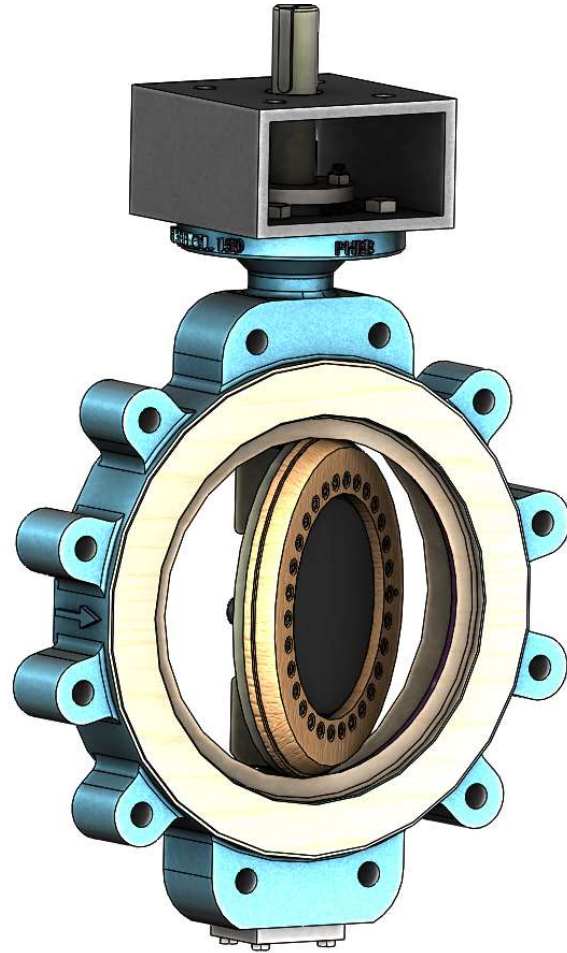

## Size Range

Size : DN50 to DN750

Rating : Class 150 to 600

Ends : Flanged, Wafer, Lugged





# Different Type of Ball Valves

# Trunnion Ball valves (6" to 16" in 150# to 600#)



**Project : Pan Ocean ( EFP & LPG in Nigeria),  
through Weatherford & FODE, UK**



# 3 way L Port valves ( Identical & Mirror Type)

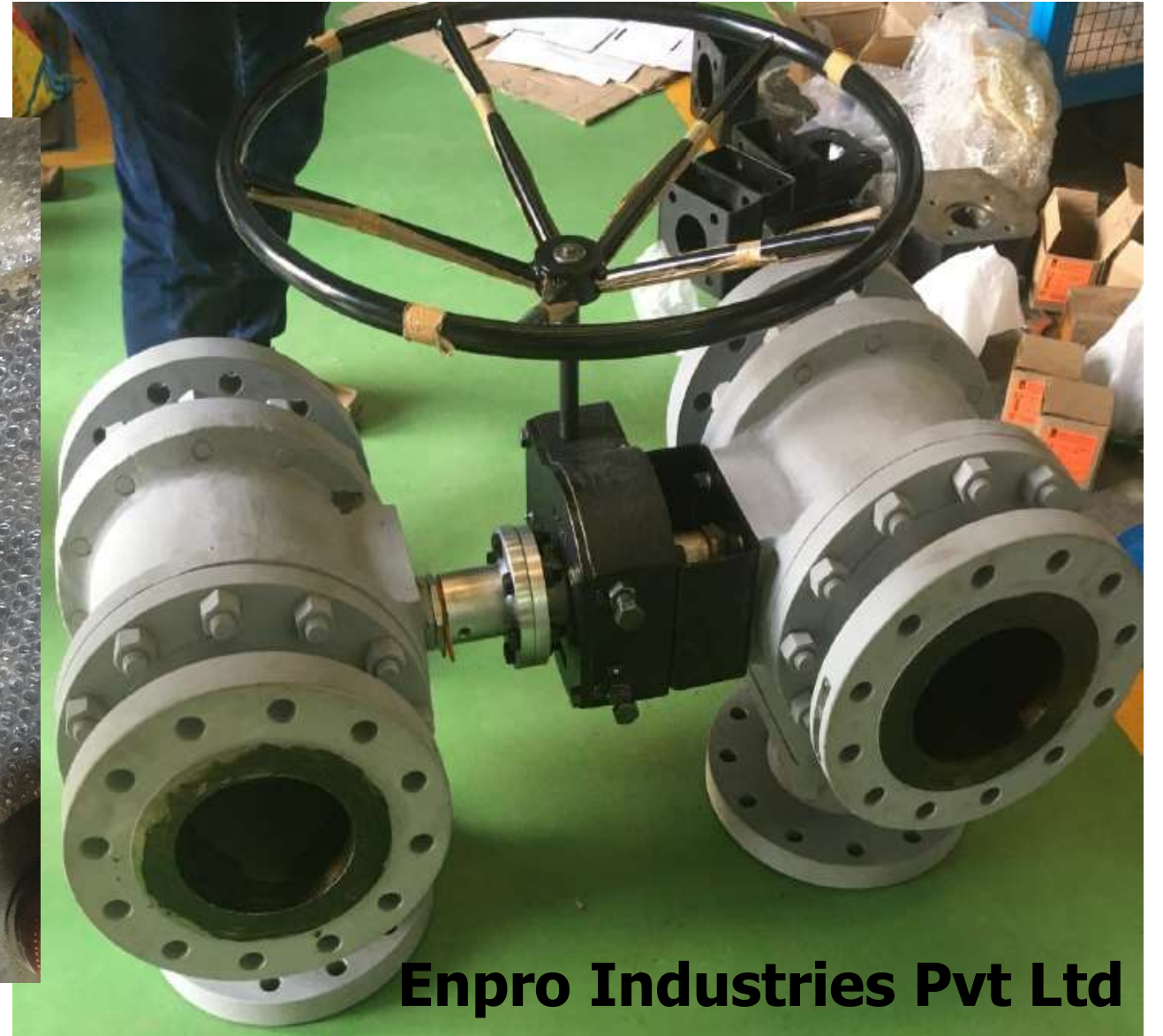

**Enpro Industries Pvt Ltd**



# Organic Coated Ball valves with Duplex Trim (1/2" to 12" in 150#)



**Petrobras Presalt FPSOS P66-71 Project, Brazil  
through Frames Gas Processing, Holland**







# Trunnion Ball Valves sizes upto 20" / 600#, Valves painted with NACE level 3



**OCTP Ghana Project through VME Singapore**

# Trunnion Ball Valves sizes upto 12" / 2500#, Valves painted with NACE level 3



**OCTP Ghana Project through Siemens Singapore**



# Aluminium Bronze (C95800) Ball Valves ( 1/2" to 6")



**Kaombo and OCTP Projects in Ghana through Siemens Singapore**



# Double Block & Bleed Valves of 2500# with lip seals



FPSO Pioneiro de Libra - Petrobras in Santos Basin, Brazil through London Marine Consultant ( LMC), UK



# Fully Jacketed Ball Valves (1" to 8")

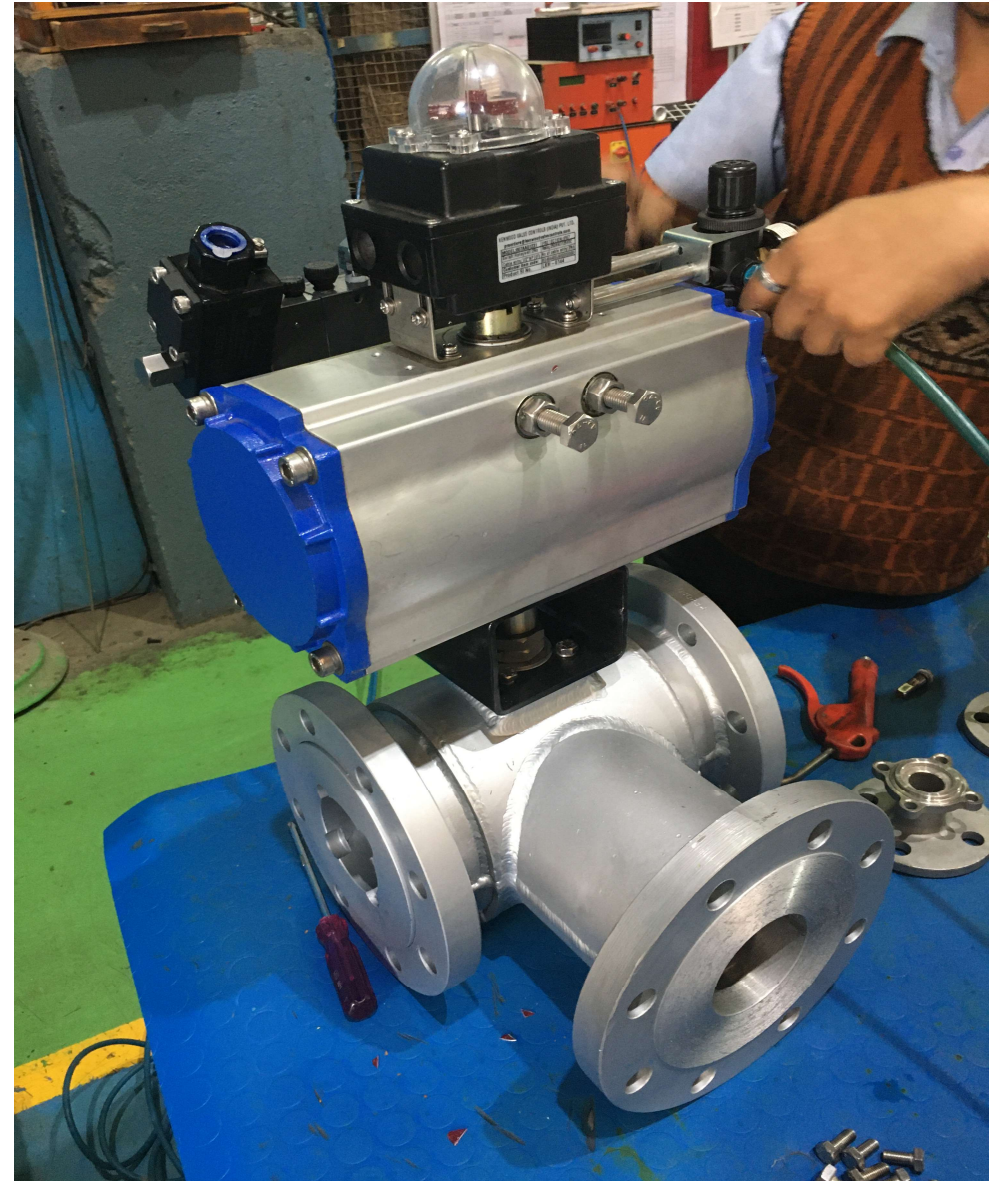



# Ball Valves with Lip Seal and Bonnet Extension for low Temperature Application



Shot on OnePlus  
Powered by Dual Camera



Shot on OnePlus  
Powered by Dual Camera



# Trunnion Ball valves (14" 600# in Carbon Steel & Stainless Steel)



ONGC - KG-DWN 98/2 ONSHORE MEG AND GAS PIPELINE TERMINAL ,  
Kakinada ( through Tata Projects Limited)

# Valve Automation Integration Partner *for* **SUSIN I-Tork**



*energy ahead...*





# ESDV Ball valve of 10" FB 150# in Duplex



TEN DEVELOPMENT PROJECT (TULLOW GHANA LIMITED) / MODEC Singapore, through GPS, Singapore

# Automated Metal Seated Ball Valves with TCC coating, (3" #1500 ), with special drain, vent & purging connection



**AARTI INDUSTRIES LTD - DAHEJ DIV - SEZ UNIT**



# Metal seated Automated ON-OFF Valves (6" & 8" PN 40 & PN 63)



**PKN ORLEN S.A for Paraxylene upgrade through –  
ANB, Poland**

# Automated Ball valves (2" to 10" in 150# to 600#)

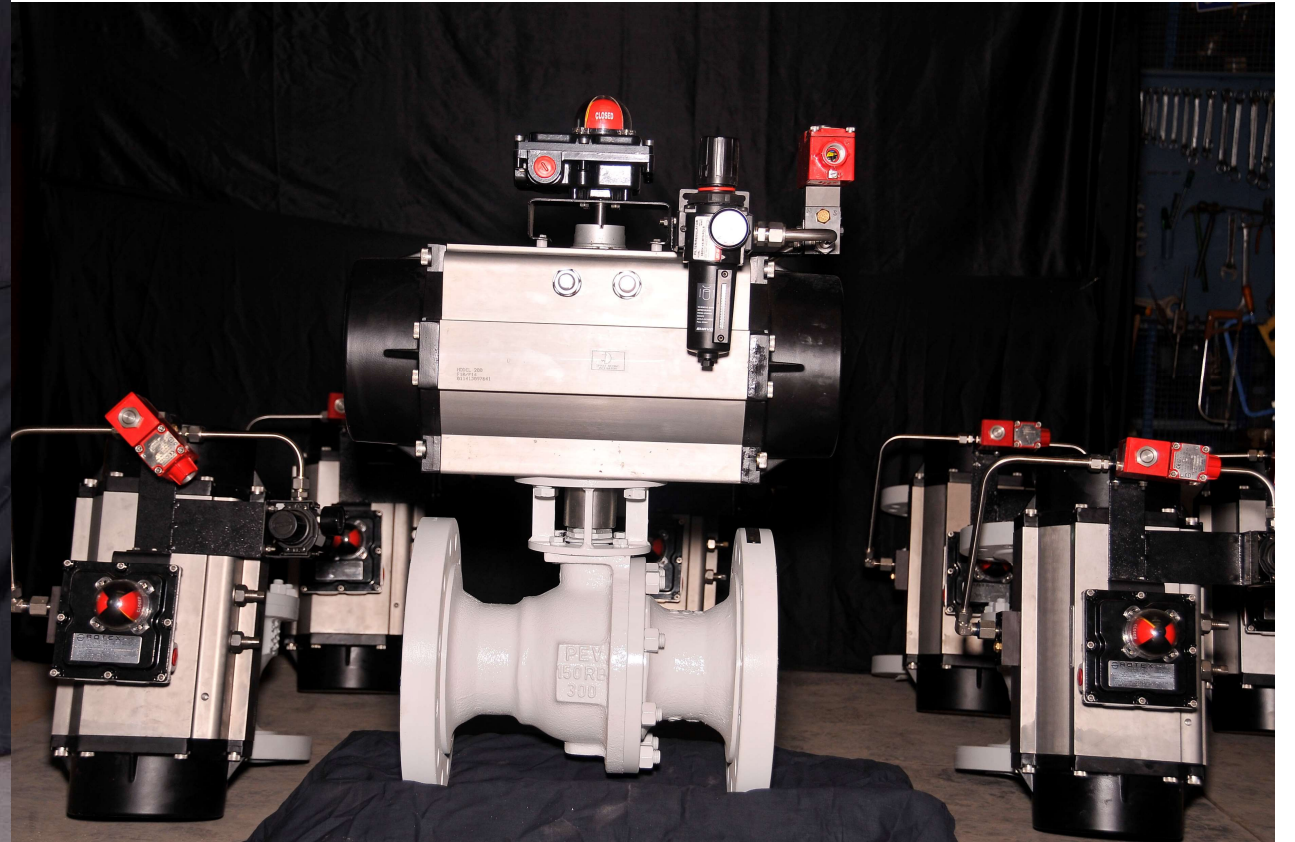

**Pan Ocean( EFP & LPG in Nigeria ), through  
Weatherford & FODE, UK**



# Automated Ball valves (8" #900)



**Defense Research & Development Laboratory (DRDL)**

# ESDV Ball valves (8" 300#)



**Laying of 8" X 8.5 KM Pipeline from Trishna EPS to Monarchak GMS" of ONGC through OVAL Projects, India**



# Full Stainless Steel Trunnion Ball Valves upto 20" 150#



**Kivu56 Methane Gas to Power  
Project, Rwanda**



# Special Type of Ball Valves



# Fully Welded Ball Valves with Stem Extension

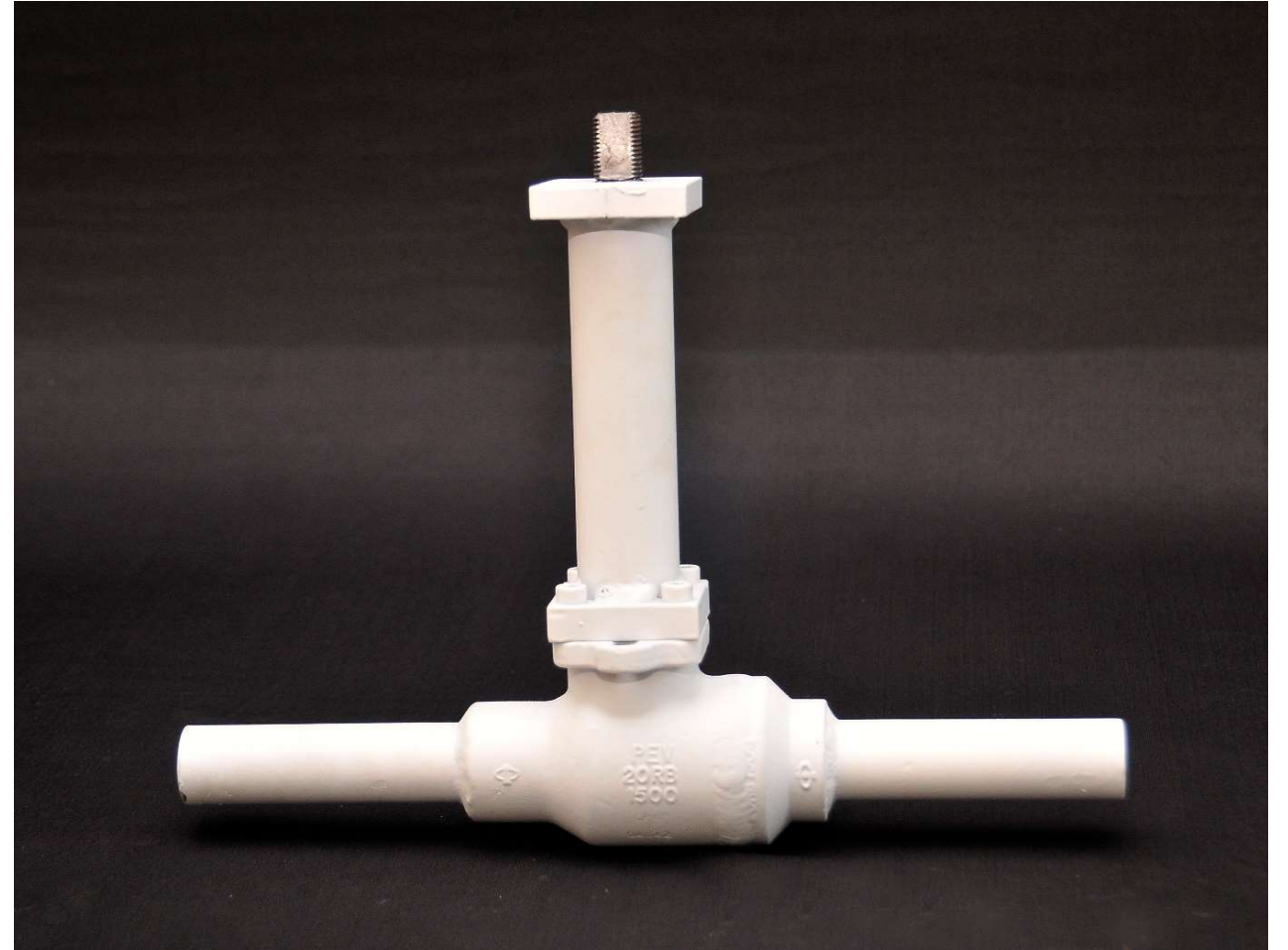

PEMEX, Mexico / THE LOW COMPRESSION PLATFORMA LITORAL - A (CB - LITORAL - A) through Frames Gas Processing B.V., Holland

# Top Entry Ball Valves (600#)



**LNG ANGOLA PROJECT ( Bechtel, USA )**



# Double Block & Bleed and Single Block & Bleed Ball Valves

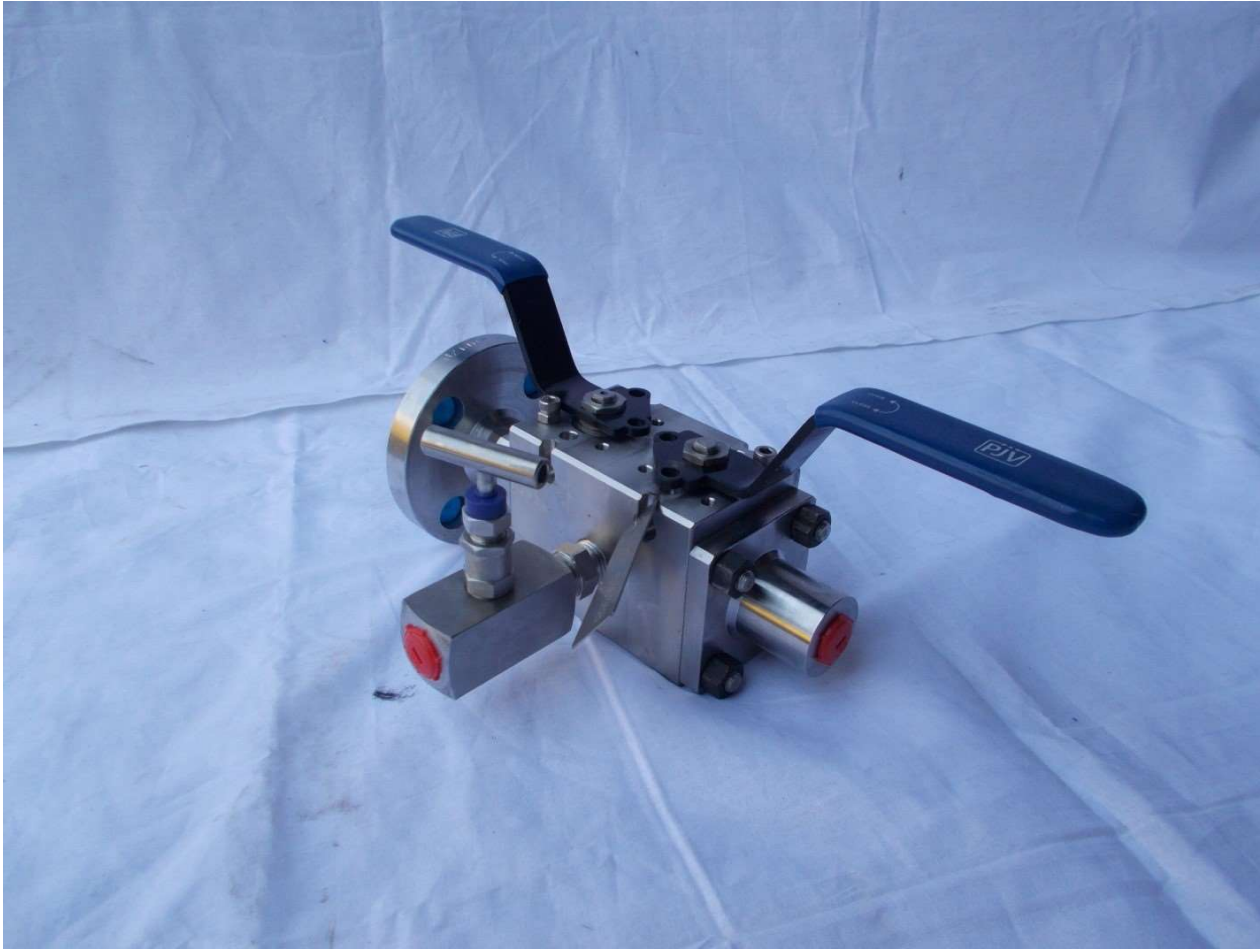

**Kaombo Ghana, through Siemens Singapore**

# Special Metal Seated Ball Valves for Iron Ore Slurry 3" 1500# & 3" 150#

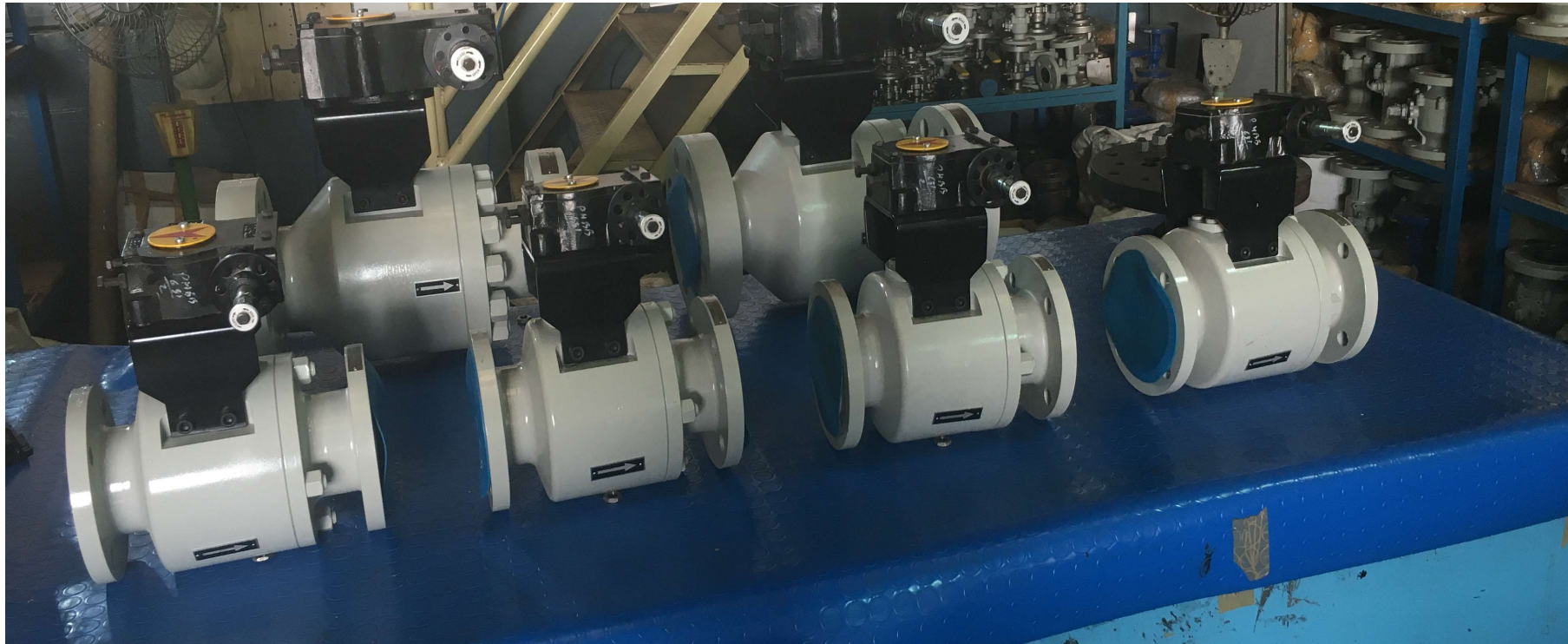

**ArcelorMittal Nippon Steel India Limited**



# 4 Way Ball Valves



**For Project SONTRA 1A & 1B HYDRO POWER, Indonesia**



# Credentials



**AARTI INDUSTRIES LTD-DAHEJ DIV-SEZ UNIT**

FACTORY ADDRESS :- PLOT NO.Z/103/H, DAHEJ SEZII, TAL,VAGRA,DIST.BHARUCH-392130,BHARUCH-392130  
 TELEPHONE No.:-022 - 67976666 FAX No.:-  
 ADMIN OFFICE :- UDYOG KSHETRA,2nd FLOOR,MULUND-GOREGAON LINKROAD, L.B.SMARG,MULUND (W),MUMBAI-400 080.  
 TELEPHONE No.:-(022)67976666,67976697 FAX No.25653234, 25904806

**PURCHASE ORDER**

C.S.T No. :-	RANGE :-
VAT TIN No. :-	DIVISION :-
NEW E.C.C.No. :-	COMMISSIONERATE :-
PAN NO. :-	
PJV Valves Pvt. Ltd. Plot No: 238-239, Sector 10 Pune PUNE MH 411026 REPUBLIC OF INDIA	PURCHASE ORDER NO :- 4550180805 DATE :- 23.03.2017 PAYMENT TERMS :- 50% Adv Pmt Bal Against Proforma Invoice SPECIAL INSTRUCTIONS :-FREIGHT EXTRA AT ACTUAL
C.S.T No. :-	
VAT TIN No. :-	

Dear Sir,

We have pleasure to entrust you with our order for the Goods mentioned below and shall appreciate your executing the same as per instruction given herein.Please return duplicate copy of this order duly signed as the acceptance of this order.

Sr.No.	ITEM DESCRIPTION	QUANTITY	UNIT	RATE(INR)	Amount
1	VALVE ON/OFF BALL MOC-SS317L CLASS:1500# BALL VALVE, 3" WITH PNEUMATIC ACTUATOR RATING - 1500# CONSTRUCTION- METAL SEATED, CONNECTION - FLANGED, TOUNGE & GROOVE, BODY - ASTM A351 GR. CG3M. BALL - ASTM A351 GR. CG3M + TCC SEAT - SS317L + TCC SEALING - GRAPHITE  VAT NO:24250500002 CST NO:24750500002 Excise exempted Against ARE-I +CST exempted Against Form - I being Supply to SEZ.  Quotation: PJV-D-237-12-16-REV 00 Del Sch: 12-14 WEEKS Indent   PR :   13051596 - 10	2,000	NOS		

VAT	0.00	TOTAL	1,100,000.00
CST	0.00	DISCOUNT	0.00
TCS	0.00	EXCISE	
Screen Print Charge	0.00	INSURANCE	0.00
		PACKING & FORWARDING	0.00
		FREIGHT	0.00
SALES TAX : FORM:-		PURCHASE ORDER VALUE	1,100,000.00

**AARTI INDUSTRIES LTD- DAHEJ-NEO SEZ UNIT**

FACTORY ADDRESS :- PLOT NO.Z/103/H, DAHEJ SEZII, TAL,VAGRA,DIST.BHARUCH-392130,BHARUCH-392130  
 TELEPHONE No.:-022 - 67976666 FAX No.:-  
 ADMIN OFFICE :- UDYOG KSHETRA,2nd FLOOR,MULUND-GOREGAON LINKROAD, L.B.SMARG,MULUND (W),MUMBAI-400 080.  
 TELEPHONE No.:-(022)67976666,67976697 FAX No.25653234, 25904806  
**GSTIN : 24AABCA2787L2ZH PAN No. : AABCA2787L**

**PURCHASE ORDER**

PHBB VALVES PVT LTD PLOT NO. 238, 239 SECTOR 10, PCNTDA, BHOSARI, PUNE PUNE MH 411026 INDIA  GSTIN : 27AAHCP0913H1ZK Contact No.: 9028096017,9033119988 E-mail : vivek.kulshrestha@phbbvalves.com	PURCHASE ORDER NO :- 4550328832 DATE :- 27.11.2020 PAYMENT TERMS :- Pay Within 30 days of date on Invoice SPECIAL INSTRUCTIONS :-Free on Road/Rail LATE DELIVERY TERMS :-LIQUIDATED DAMAGES FOR DELAYED DELIVERY SHALL BE APPLICABLE @ 1% OF PO VALUE PER WEEK OF DELAY, MAXIMUM UPTO 10% OF PO VALUE
--	---

Dear Sir,

We have pleasure to entrust you with our order for the Goods mentioned below and shall appreciate your executing the same as per instruction given herein. Please return duplicate copy of this order along with supplier code of conduct duly signed as the acceptance of this order.

Sr.No.	ITEM DESCRIPTION	QUANTITY	UNIT	RATE(INR)	Amount
1	ZBLK XV BALL FB-2W-S 3" 1500# SS317L NJK	1,000	NOS		

Sr.No.	ITEM DESCRIPTION	QUANTITY	UNIT	RATE(INR)	Amount
	SB07 MOUNTING BRACKETS ( VTS ) : CS + POWDER COATED DIAPHRAGM ( VTS ) : AS PER CATELOGUE Make & Model Name: PHBB FBV-SE HSN Code: 8481 GST Rate: 0.00 % Quotation: PHBB-D-294-07-20 Final  25.11.2020 Del Sch: Delivery by 19.02.2021 Indent   PR :   13110941 - 10				

IGST	0	TOTAL	\$10,000.00
CGST	0	DISCOUNT	0.00
SGST	0	INSURANCE	0.00
UGST	0	PACKING & FORWARDING	0.00
Basic TCS	0.00	FREIGHT	0.00
Gross TCS	0.00	PURCHASE ORDER VALUE	\$10,000.00

**Kindly confirm your Address, GSTIN as mentioned in our PO. For any correction/changes, revert/reply immediately to the concerned purchase executive & to rajesh.gothi@aartigroup.com**

**For all other correspondence with reference to this PO, kindly contact (Contact details: , )**



SELLER: PJV VALVES PVT. LTD.  
PLOT NO. 238-239, SECTOR 10,  
PCNTDA, BHOSARI  
PUNE 411 026, MAHARASHTRA, INDIA  
TEL : +91 (0)20 6999 6017

Date: 28.08.2017

**Order No.: 17-172\_rev.02**

ref.: PJV-E-002-01-17 REV 06 dtd 03.08.2017

CONSIGNEE: ANB Sp z o.o.  
ul. Zerzeńska 36  
04-787 Warszawa  
tel.: + 48 606-823-712

BUYER: ANB Sp. z o.o.  
ul. Zerzeńska 36, 04-787 Warszawa  
tel. +48 22 612 16 16 FAX: +48 22 612 29 30  
e-mail: anb@anb.com.pl, www.anb.com.pl  
VAT no PL 526006893  
Certyfikat nadany przez TÜV NORD CERT GmbH



MODE OF TRANSPORT: To be agreed additionally  
TERMS OF DELIVERY: ~~FCA Pune, India~~ **FOB Mumbai** **Delivery on or before the 09.10.2017**  
MODE OF PAYMENT: **20% advance with PO, balance 80% before despatch**

Pos.	DESCRIPTION OF GOODS	QUANTITY pcs	UNIT PRICE	VALUE
1	Ball valve + pneumatic actuator + solenoid valve + air filter regulator + Emerson DVC6200F positioner + necessary mounting and tubing 1-1/2"	12	\$3 392.00	\$40 704.00
2	Ball valve + pneumatic actuator + solenoid valve + air filter regulator + Emerson DVC6200F positioner + necessary mounting and tubing 1/2"	3	\$3 268.00	\$9 804.00
3	Ball valve + pneumatic actuator + solenoid valve + air filter regulator + Emerson DVC6200F positioner + necessary mounting and tubing 1/2"	12	\$3 542.00	\$42 504.00
<b>Total value (packing included):</b>				<b>\$93 012.00</b>

End user: **Aluminium Bahrain B.S.C. / Kingdom Of Bahrain**

Documentation: Quality documentation: As per EN 10204-3.1 for pressure containing parts

Technical documentation:  
- Dimensional Drawings  
- Instruction Manuals in English

Together with the goods: packing list  
The original of invoice is required to be sent to us immediately the dispatch has been made.  
**OUR GENERAL CONDITIONS OF PURCHASE OVERLEAF CONSTITUTE AN INTEGRAL PART OF THE ORDER**

Availability of shipping 1st package:  
Item 1: 4 pcs  
Item 2: 1 pcs  
Item 3: 4 pcs  
In separate dispatch readiness Ex Works for September 21st.



**CZŁONEK ZARZĄDU**  
Pawel Schetner

**Modification of positioners - Fieldbus Logic, Ex d gland + 25 USD to unit price**

**ArcelorMittal Nippon Steel India Limited**

(Formerly Essar Steel India Limited)

AM/NS PELLETS VIZAG  
Near Flyover, Scindia Road  
Visakhapatnam-530004  
Andhra Pradesh, India.  
Ph : 0891- 2523213  
Fax : 0891-2559383

VAT/LST NO : 37810137526  
CST NO : 37810137528  
ECC NO : AAACE1741PXM002  
SERVICE TAX REGN NO : AAACE1741PST003  
RANGE : RANGE-III A, 3RD FLOOR, MVP  
COLONY, VISAKHAPATNAM - 530  
PAN NO : AAACE1741P  
CIN:U27100GJ1978FLC013787

**AM/NS  
INDIA**

**PURCHASE ORDER**

PO NO: AM/NS-VIZ/VMC/4500286077  
DATE : 14.10.2020  
GSTIN : 37AAACE1741P1ZG

SUPPLIER'S NAME : PHBB VALVES PRIVATE LIMITED

SR.NO.	MAT.CODE	QTY	UNIT	RATE/UNIT (INR)	AMOUNT (INR)
--------	----------	-----	------	--------------------	-----------------

00010 300141673 2 Number 0 / 1 NO  
VALVE,BALL,3INCH,250KG/CM2,FLANGED,CS

VALVE,BALL  
SIZE:3  
PRESSURE RATING:250  
END CONNECTION:FLANGED  
OPERATION:MANUAL  
BODY MATERIAL:CARBON STEEL  
NUMBER OF PORT:TWO  
TYPE OF SEAT:A182-F22/H.F  
BALL MATERIAL:410S.S/RAM31  
PACKING MATERIAL:316S.S/GRAFOIL  
SEAT MATERIAL:A182-F22/H.F  
MODEL:B8C1-RF-FP  
ADDITIONAL INFORMATION:PS2 DISCHARGE DRAIN

00020 300060453 4 Number / 1 NO 0  
VLV,BALL,3,150,FLGD,CS

VALVE,BALL  
SIZE : 3 INCH  
PRESSURE RATING : 150 LBS  
END CONNECTION : FLANGED  
OPERATION : MANUAL  
BODY MATERIAL : CS  
TYPE OF PORT : FULL  
TEMPERATURE RATING : 300 DEG.C  
SERVICE : DUSTY ATMOSPHERE OF IRON FINES

Total net value excl. tax INR 1,721,998.00



**Pjv Valves Pvt Ltd**  
PCNTDA, Bhosari, 0  
Plot No.- 238, 239, Sector 10,  
Pune, Maharashtra  
411026  
INDIA

EMAIL to contact@pvalves.com  
Your Partner no: 110000381  
Tel:020-6999-6017  
Fax:0

**Purchase Order No. 670000331 Created 30.01.2017**

Your quotation/Dated: PJV-D-REV0/25.01.2017

Please state our order number on all invoices, challans & correspondence  
We order under our enclosed purchasing terms.

Item No.	Quantity	Item Description	Value(INR)
00010	4.000 EA	1" Hastelloy C-22 Ball Valve Body SOTG	
00020	6.000 EA	2" Hastelloy C-22 Ball Valve Body SOTG	
00030	2.000 EA	3" Hastelloy C-22 Ball Valve Body SOTG	
00040	5.000 EA	4" Hastelloy C-22 Ball Valve Body SOTG	
00050	4.000 EA	1" Hastelloy C-22 Ball Valve Body SORF	
00060	2.000 EA	2" Hastelloy C-22 Ball Valve Body SORF	
00070	2.000 EA	3" Hastelloy C-22 Ball Valve Body SORF	
00080	3.000 EA	4" Hastelloy C-22 Ball Valve Body SORF	
00090	4.000 PCE	VALVE BALL 1" 2 PC HAST C FULL BORE	
00100	5.000 PCE	VALVE BALL 1 1/2" 2 PC HAST C FULL BORE	
00110	1.000 PCE	VALVE BALL 2" 2 PC HAST C FULL BORE	
00120	5.000 PCE	VALVE BALL 3" 2 PC HAST C FULL BORE	
00130	1.000 PCE	VALVE BALL 4" 2 PC HAST C FULL BORE	

Base Amount  
Item Total Value

Items Total Value 3913570.00  
PO Total Value 3913570.00

**IN WORDS : INR THIRTY NINE LAKH THIRTEEN THOUSAND FIVE HUNDRED SEVENTY RUPEES**

Please pay attention to our invoice address. Invoices with wrong addresses cannot be handled and will be returned to you.

The agreed payment terms will start only after the receipt of the corrected invoice :

**Terms of Payment** Payment Terms:  
\*

**Terms of Delivery**

**Delivery Period** Delivery period is the essence of the PO. Supplies should be completed within the stipulated delivery period as mentioned below.

Deccan Fine Chemicals (India) Pvt.Ltd.  
8-2-293/82/A/74A,  
Road No#9, Jubilee Hills,  
Hyderabad-500033,  
Tel:0091-40-23601035,  
Fax:0091-40-23601071.

Procurement Contact:  
Name:Manthan Patel  
Tel:+912646661024  
Email:Mathan.patel@deccanchemicals.com

Page 1 of 14

**PHBB Valves Private Limited**  
PLOT NO- 238-239, SECTOR 10, PCNTDA,  
Bhosari  
Pune, Maharashtra  
411026  
INDIA  
GST No.: 27AAHCP0913H1ZK

EMAIL to rahul.agrawal@phbbvalves.com  
Your Partner no: 1100002034  
Tel:9028096017  
Fax:

**Purchase Order No. 6700005489 Created 16.05.2020**

Your quotation/Dated: 166-05-20/02.05.2020

Please state our order number on all invoices, challans & correspondence  
We order under our enclosed purchasing terms.

Item No.	Quantity	Item Description	Value(INR)
00010	4.000	MPL ACT.ON OFF VALVE SS316 NIBR	
00020	3.000	Our Material No:20491414	
00030	3.000	ACT.ON OFF VALVE SS316 NIBR	
00040	5.000	Vendor Name:- PHBB Valves Private Limited	
00050	2.000	Type : Full Bore, Fire Safe Ball Valves	
00060	4.000	Side Entry, Two-piece construction,	
00070	3.000	two way Floating Mounted	
00080	4.000	Ball Design with Anti Blowout Stem and Anti	
00090	5.000	Static Device with	
00100	5.000	ISO 5211 Actuator Mounting Pad	
00110	5.000	Pressure Rating : 150#	
00120	3.000	End Connection : Flanged RF	
00130	2.000	Leakage Class : VI	
00140	4.000	Material of Construction	
00150	5.000	Body : ASTM A 351 Gr. CF8M	
00160	3.000	Ball : SS 316	
00170	4.000	Stem : SS 316	
00180	1.000	Seat : RPTFE	
00190	1.000		

Note: Prices are exclusive of SOV, AFR and Limit Switch Box. If required, we will release separate order for the same.

Base Amount  
Integrated GST 18.00 %  
Item Total Tax Value  
Item Total Value

Tax total Value  
Items Total Value 1  
PO Total Value 1

**IN WORDS : INR SEVENTEEN LAKH TWENTY THREE THOUSAND EIGHT HUNDRED FIFTY TWO RUPEES FIFTY SIX PAISE**

Please pay attention to our invoice address. Invoices with wrong addresses cannot be handled and will be returned to you.

The agreed payment terms will start only after the receipt of the corrected invoice :

**Terms of Payment** 100% Against Goods Receipt, Payable within 30 Days  
**Terms of Delivery** CIF(-) Deccan - Ankleshwar Site

Deccan Fine Chemicals (India) Pvt.Ltd.  
8-2-293/82/A/74A,  
Road No#9, Jubilee Hills,  
Hyderabad-500033,  
Tel:0091-40-23601035,  
Fax:0091-40-23601071.

Page 1 of 37





**IN-LINE ENGINEERING & MARKETING SERVICES**

44/19, SHYAMNAGAR ROAD, 'DASVILLA', KOLKATA - 700 055  
 MOBILE : 9830070702 | WHATSAPP : 8582803270  
 E-MAIL : adutta@cal2.vsnl.net.in & aduttainline@gmail.com

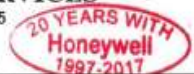

MAT - PUR/F/02/00  
 Vendor



**Isagro (Asia) Agrochemicals Pvt. Ltd.**

Regd. Off: 3rd Floor, Kalpataru Square, Kondivita Lane, Unit No 32, R K Mandir Road, J B Nagar,  
 Andhari East, Mumbai-400059  
 Tel : 91 2249115656/57/58, Fax : 91 2249115665

**LETTER OF INTENT (REVISED)**

**LOI No.: LOI-20001/J-20011/PHBB - Date: 27/06/2020**

PHBB Valves Private Limited  
 (Formerly PJV Valves Private Limited)  
 Plot No.238-239, Sector 10,  
 PCNTDA, Bhosari,  
Pune 411026

M: 09820025082

tanagarajan@phbbvalves.com

Attn : Ms.Kirti Bhutkar

Dear Sirs,

W.r.t. your e-mail of date (27/06/2020), we are pleased to issue this Revised LOI for your doing the needful:

Sl.No.	Model / Item Description	Qty Nos.	Unit Price (INR)	Total Price (INR)
1	8" Trunion Ball Valve, duly assembled with Pneumatic Actuator, Solenoid Valve, Limit Switch Box, Air Filter regulator, QEV and necessary Mounting & Tubing	1	0	
2	4" Trunion Ball Valve, duly assembled with Pneumatic Actuator, Solenoid Valve, Limit Switch Box, Air Filter regulator, QEV and necessary Mounting & Tubing	1		
<b>Total =</b>				<b>16,28,058.00</b>

(INR Sixteen Lacs Twenty Eight Thousand Fifty Eight only)

Terms & Conditions

- Price basis: Ex-Works, Pune
- P&F: Included in above price
- GST: Extra @ 18%
- Freight: To Pay
- Delivery: Within 16 weeks, ex-works from receipt of drawing & QAP/ITP approval
- Delayed Delivery Clause: @ 0.5% per week or part thereof, maximum 5% of basic order value
- Payment Term: 15% Advance after issuing the all relevant technical documents duly 'Approved' by the competent authority.  
 Balance by 30 days PDC, prior to dispatch
- Third Party Inspection: Shall be provided and arranged by you in your factory (Pune-411026) free of any charge.  
 However, all to-and-fro fare, boarding / lodging, local conveyance etc. will be borne by us
- Warranty / Guarantee: 18 / 12 months from the date of despatch / commissioning, whichever is earlier
- Road Permit: Applicable
- Invoice / Shipment Details: Will furnish later

Thanking you,

Yours faithfully,

For IN-LINE ENGINEERING & MARKETING SERVICES



(A.DUTTA)  
 Authorised Signatory

**PURCHASE ORDER**

To:	Point of Delivery:	Order Details:
PHBB VALVES PRIVATE LIMITED PLOT NO 238-239, SECTOR 10, PCNTDA, BHOSARI, PUNE 411026 MAHARASHTRA INDIA Vendor Registration No.: 27AAHCP0913H1ZK	Isagro (Asia) Agrochemicals Pvt. Ltd. Plot No - 640 G.I.D.C. IND. Estate. Panoli 394116 Bharuch GUJARAT INDIA  Excise Details: ECC No. :AAACIB431LXM001 Range :III Division :XI ANKLESHWAR Commissionerat :VADODARA-II Registration :24AAACIB431L1Z1	Location : Panoli Order No. : 4600000358 Order Date : 16.03.2020 Req No : 1000004101 Req Date : 13.03.2020 Pan No : AAACIB431L Capex No. : 700071 IEC code No : 0301044040

Payment Terms : 30 Days From GRN Date

Incoterms : AT OUR PANOLI SITE

Sr. No.	Description	Quantity	UoM	Del. Date	Rate	Amount (INR)
11	CS BALL VALVE, ASA#150 #F/T, 2" DIA Item Code : 30007359	15	NOS	01.04.2020		
12	CS BALL VALVE, ASA#150 #F/T, 3" DIA Item Code : 30007361	25	NOS	01.04.2020		
13	SS316 BALL VALVE, ASA#150#F/E, 1 1/2"DIA Item Code : 30007381	10	NOS	01.04.2020		
14	SS316 BALL VALVE, ASA#150#F/E, 2" DIA Item Code : 30007388	7	NOS	01.04.2020		
15	CS BALL VALVE, ASA#150 #F/T, 1" DIA Item Code : 30007357	12	NOS	01.04.2020		
16	CS BALL VALVE, ASA#150 #F/T, 2" DIA Item Code : 30007359	10	NOS	01.04.2020		
17	CS BALL VALVE, ASA#150 #F/T, 3" DIA Item Code : 30007361	2	NOS	01.04.2020		
18	SS316 BALL VALVE, ASA#150#F/E, 1/2" DIA Item Code : 30007386	4	NOS	01.04.2020		
19	SS316 BALL VALVE, ASA#150#F/E, 1" DIA Item Code : 30007383	103	NOS	01.04.2020		

Remarks :  
 # QTN / QCF ATTACHED.  
 # PROJECT PURCHASE.  
 # PHBB MAKE.

TOTAL : 2,318,010.00  
 Integrated GST 18.00 % : 417,241.80

Total Order Value (INR) : 2,735,251.80

Total Order Value (In Words): Twenty Seven Lakh Thirty Five Thousand Two Hundred Fifty One And Eighty Only

- Please acknowledge the acceptance of this order.
- Please quote our Purchase order number and date on all challans, Bill and correspondence.
- Please refer terms & conditions written overleaf.

**For Isagro (Asia) Agrochemicals Pvt. Ltd.**

*[Signature]*  
 AUTHORIZED SIGNATORIES

\*This is a computer-generated document. No Signature is required.



BILL TO ADDRESS:  
 JUBILANT INGRESIA LIMITED (UNIT-1)  
 SPECIFIC PLOT NO. P1-L1, PLOT-5  
 VIJAYAT, TALUK VAGRA  
 DIST. BHARUCH, GUJARAT-392012  
 State : 24 Gujarat  
 GSTIN : 24AACJ6722DZV

Approved Copy

COMPANY : 581 ENGINEERING - BHARUCH - UNIT-1

PURCHASE ORDER

PO No. : 440231 Order Dt: 09-03-2021 Project :	Delivery Date : 21-05-2021 Buyer : Prasad Bhalme Reference A : R41719/Q45527/G39877	Transaction Type : Domestic Inter State Nature of Transaction : From Registered Vendor Reference B : PR:220114/Robin Esho
Supplier/Vendor: HP0903	Ship From :HP0903 S01	Ship To :
PHB VALVES PRIVATE LIMITED PLOT NO.238-239,SECTOR 10, PONTDA, BHOSARI, PUNE Pincode : 410026 State : 27 Maharashtra GSTIN : 27AACPO913H1ZK Email : contact@phbvalves.com	PHB VALVES PRIVATE LIMITED PLOT NO.238-239,SECTOR 10, PONTDA, BHOSARI, PUNE PUNE Pincode : 410026 State : 27 Maharashtra GSTIN : 27AACPO913H1ZK Email :	JUBILANT INGRESIA LIMITED (UNIT-1) SPECIFIC PLOT NO. P1-L1, PLOT-5 VIJAYAT, TALUK VAGRA DIST. BHARUCH, GUJARAT-392012 Pincode : State : 24 Gujarat GSTIN : 24AACJ6722DZV

Dear Sir,  
 Please supply the following goods as per the terms and conditions stipulated below and overleaf.

Item Code Description	HSN	Quantity	Unit Price	UOM	Basic Amount	Disc. Amt	Other Charge1	Other Charge2	Taxable Value	Total Amount
2778010900 VALVE BALL SS316 3" 900# TOC VALVE BALL, SS316, 3", FULL BORE, 900#, BALL&SEAT: TOC, F/E-TONGUE&GROOVE	8481	1.000	311195.000	NO	311195.000	0.00 (0.00%)	0.00	0.00	311195.00	311195.000

IGST "NIL AGAINST BOND/LUT, ZERO RATED TAX-GEZ"

Jubilant Bharuch is an ISO50001:2018 Certified company. All material supplied for the company should be Energy efficient and should be supplied as per our specifications only. The material supplied Off-specs is liable to be rejected.

Grand Total : (INR) ( THREE LAKHS ELEVEN THOUSAND ONE HUNDRED NINETY FIVE ONLY ) 311195.00

Tax : Nil  
 Reverse Charge Applicable : NO  
 TDS Applicable(1%) (Yes/No) :

Delivery Terms:D06 DAP - DELIVERED AT PLACE Payment Terms:V63 MME-30-DAYS FROM MTC RECPT

- INDENTOR
- 1.State our Order and Item Number on all invoices
  - 2.All columns of E-way bill to be filled.
  - 3.Time is the essence of this Purchase Order
  - 4.In case of Material rejection,Jubilant will send back/book the consignment on "To Pay" basis at supplier risk and the copy of lorry receipt of the Transporter will be consider as a proof of material.

Place :Bharuch Date : 13-03-2021 FOR JUBILANT INGRESIA LIMITED (UNIT-1)

Prepared By \_\_\_\_\_ Checked By \_\_\_\_\_ AUTHORIZED SIGNATORY



HAL Offshore Ltd,  
 B-KUDAVI KARUNA SURVODOLONE,  
 HEDUVA HANUMAT, PAJAVASANA, MEHSANA 380002  
 PHONE: Fax:

PURCHASE ORDER

PO No. : PMES/1508/0006	Project : MEHSANA
Date : 04-10-2019	Project Sub Category : PIPING
PHB VALVES PVT LTD PLOT 238-239, SECTOR 10, PONTDA, BHOSARI, PUNE 411016 Phone : 982025982 Fax :	Delivery At : SOMNATH GAS OILM OILFIELD VILLAGE - PUNASAR - DIST - JAGODHAR MEHSANA - 380002 INDIA
GST Registration No. : 27AACPO913H1ZK	Amendment Details : 1/Date :
Contract No. / BY: BHARUCH TA : 950027042	Delivery Terms : F.O.B SITE
Delivery Period/Date : /12-14 WEEKS FROM THE DATE OF MANUFACTURING (CLERICAL)	Vendor Code No. : VEND-01803
Certificate : ALL NECESSARY MATERIAL & TEST CERTIFICATE REQUIRED SHALL BE IN ACCORDANCE WITH ONGC REQUIREMENT	Supplier Proposal Ref No. : REFER EMAIL DATED 04-OCTOBER-2019
Inspection By : ONGC/INE APPROVED	Insurance : IN HAL SCOPE
Inspection At : SITE/OUTDOOR WORKS	HAL GST No. : 24AACPO144H1ZC
Liquidated Damages : 05 % PER WEEK ON UNDELIVERED ITEM upto 5 % MAXIMUM (10)	HAL PAN No. : AACPO1440
Warranty Clause : 18 MONTHS FROM DATE OF DELIVERY OR 12 MONTHS FROM DATE OF COMPLETIONING WHO EVER IS EARLIER	Customs Code : BALL VALVES

Sl. No.	Product Description	HSN / SAC	Qty.	UOM	Unit Price INR	Disc %	Total Basic Amount After Disc	CGST		SGST		IGST		Total Amount INR
								Rate	Amount	Rate	Amount	Rate	Amount	
1	SUPPLY OF BALL VALVE AS PER ATTACHED SPECIFICATION (344 NUMBER)	848130	1.00	LOT	311195.00	0.00	311195.00	0%	0.00	0%	0.00	18%	56015.10	32,28,413.40
							18,00,466.00	Total Material cost in INR				32,28,413.40		

Packing & Forwarding charges	Inclusive
Freight charges	Inclusive
CGST	0.00
SGST	0.00
IGST	5,60,151.40
Inspection Charges	NOT APPLICABLE
Payment Terms	100 % PAYMENT AFTER INSPECTION BEFORE DESPATCH

IN WORDS : \*\*\*\*\* TWENTY TWO LAKH TWENTY EIGHT THOUSAND FOUR HUNDRED THIRTEEN RUPEES AND FORTY EIGHT PAISA ONLY

Grand Total in INR 32,28,413.40

- Notes :-
- 1.MATERIAL WILL BE ACCEPTED ONLY AFTER SUCCESSFUL COMPLETION OF UPOC/ONGC TPI INSPECTION. ANY REQUIREMENTS AT THE TIME OF INSPECTION SHALL BE FULFILLED BY VENDOR.
  - 2.MANUFACTURED DATE SHALL NOT BE OLDER THAN 18 MONTHS AT THE TIME OF INSPECTION.
  3. MATERIAL WILL BE ACCEPTED ONLY AFTER SUCCESSFUL COMPLETION.
  4. MANUFACTURER TC (HARD COPY) SHALL BE PROVIDED AT THE TIME OF UPOC/ONGC TPI INSPECTION.
  5. UPON RECEIPT OF THIS PO VENDOR SHALL SUBMIT THE CAP FOR ONGC APPROVAL. INSPECTION WILL BE CONDUCTED BY UPOC/ONGC TPI AS PER APPROVED CAP. VENDOR TO COMPLY WITH ALL THE APPLICABLE AND APPROVED VALVE DATA SHEETS, APPROVED MATERIAL SPECIFICATION AND OTHER PROJECT RELATED DOCUMENTS AS ATTACHED WITH PO.

Signature of DGM Purchase & Commercial: \_\_\_\_\_ Date: 04-10-19

Signature of Project Manager: \_\_\_\_\_

Signature of VP Projects: \_\_\_\_\_





**Orseal Ltd**  
Lynstock Way, Lostock, Bolton, BL6 4QR  
Sales@orseal.com  
VAT Reg. No. 145 2667 62  
Supplier of valves for all industries



**Purchase Order  
PO-13872  
Rev 8**

Order to:  
PHBB Valves Private Limited  
Plot no: 238-239 Sector 10  
PCNTDA  
Bhosari  
Pune  
Maharashtra 411026  
India

Deliver to:  
Orseal Limited  
Lynstock Way  
Lostock  
Bolton  
BL6 4QR  
United Kingdom

Purchaser  
Champak

ENQUIRY REF: WOE 20056      ORDER DATE: 5. October 2020      OUR REF.: PO-13872      ACCOUNT NO.: P037

No.	Description	Quantity	UOM	Req. Del. Date	Unit Cost	Amount
ORS3583	2" RB Ball Valve, Cl.150 RF, St/St	112	EACH	10/10/2020		
ORS3584	4" RB Ball Valve, Cl.150 RF, St/St	4	EACH	10/10/2020	.00	0
ORS3585	6" RB Ball Valve, Cl.150 RF, St/St	4	EACH	10/10/2020		
ORS3586	1/2" Ball Valve, Cl.900 NPTF, St/St	8	EACH	10/10/2020	0	0
ORS3592/ASSY	2" Actuated RB Ball Valve, Cl.150 + KSYM-025-160-0055 Actuator + Assembly	4	EACH	10/10/2020		
ORS3593/ASSY	4" Actuated RB Ball Valve, Cl.150+ KSYM-025-220-0105 Actuator + Assembly	4	EACH	10/10/2020		
ORS3594/ASSY	8" Actuated RB Ball Valve, Cl.150 + KSYM-100-280-0785 Actuator + Assembly	4	EACH	10/10/2020		
ORS3595/ASSY	10" Actuated RB Ball Valve, Cl.150 + KSYM-400-280-1105 Actuator + Assembly	4	EACH	10/10/2020		
ORS3596/ASSY	20" Actuated RB Ball Valve, Cl.150 + KSYM-1600-435-4505 Actuator + Assembly	8	EACH	10/10/2020		

Currency code: USD      Goods Total: 360,037.20  
VAT Total: 0.00  
Total: 360,037.20

Weld repairs are not acceptable unless agreed in writing  
It is a requirement of this order that you advise us of any change to your quality status.  
This purchase order must be acknowledged within 3 days. Any discrepancies to be highlighted.

Payment terms:  
10% on approval of GA drawings  
10% on procurement of major materials  
25% on receipt of major materials (with photo's)  
45% on collection after 30 days  
10% on client's document approval (60 day payment)



OVAL PROJECTS

(A Team of Excellence For Better Future)

<b>OVAL Projects Engineering Private Ltd.</b> Bardowali, P.O. AD Nagar, Agartala, Tripura West, PIN - 799003		
<b>Revised Purchase Order</b>		
Supplier Name & Address :	Supplier Code	ONGC2019
M/s PHBB Valves Private Limited	Purchase Order No:	190000018A
Plot 238-239, Sector 10, PCNTDA, Bhosari, Pune - 411 026. INDIA.	Purchase Order Date:	16-October-2019
E-mail: <a href="mailto:contact@phbbvalves.com">contact@phbbvalves.com</a> Tel: +91 90280 96017	Quotation No:	PHBB-D-377-08-19 REV 00
Ship To: OVAL Projects Engineering Private Ltd.	Quotation Date:	02-08-2019
OVAL PROJECTS ENGINEERING PRIVATE LIMITED. Milan Chakra, P.O. AD Nagar, Agartala, Tripura West, PIN - 799003	Currency:	INR

Kind Attn: Mr. T A Nagarajan

Subject: Purchase Order for supplying of Emergency Shut Down Valve for the Project named "Laying of 8" X 8.5 KM Pipeline from Trishna EPS to Monarchak GMS" of ONGC.

Dear Sir,

With reference to your quotation through mail on 2nd August 2019 & mail for amend of price dated 20th September 2019 and subsequent follow-ups that we had with you, we are pleased to place this purchase order for supplying of Emergency Shut Down Valve for the project "Laying of 8" X 8.5 KM Pipeline from Trishna EPS to Monarchak GMS" of ONGC.

Sl. No.	Description	Size (mm)	Unit	QTY	Rate/pc in Rs.	Total Rs.
1	8" Trunnion Ball Valve, ASTM A216 Gr. WCB Body E.S.D.V. Ball Valve, Class 300#, ENP Ball, Electro Pneumatic - Single Acting. Other details as per given specification.	200	NOS	2	7	
			T. Qty.	2	Total :	
GST @ 18%						
<b>Grand Total:</b>						<b>17,86,144.76</b>

(In Word: Seventeen Lacs Eighty Six Thousand One Hundred Forty Five Rupees Only)

**Oval Projects Engineering Pvt. Ltd.**

Regd. Office : Bardowali, P.O.-A.D. Nagar, Agartala, Tripura(West), Pincode-799003  
+91-3812371011, +91-9560599033  
TIN : 16052662160, CST : 16052564251  
[www.ovalprojects.com](http://www.ovalprojects.com)  
CIN - U74900TR2013PTC00846

Old Address:

Office-UGF-A Parsvsnath Mall, Site No. 11, Sector-20A, Faridabad, Haryana, India, TeleFax : Pincode-121003

*Ganesh Dabrah*



Vendor Code : 105740  
 PHBB VALVES PRIVATE LIMITED  
 PLOT NO 238-239,  
 411026 PUNE-PUNE  
 GST No : 27AAHCP0913H1ZK

### Purchase order

PO number/date  
 4500401136 / 30.10.2020  
 GST DETAIL  
 GST No. : 24AABCP2183M2ZA  
 PAN : AABCP2183M

Please deliver & invoice to:

PI Industries Ltd... ( Manufacturer )  
 PLOT NO. SPM - 28, STRLING SEZ  
 AT & PO SAROD, TAL. JAMBUSAR  
 392180 JAMBUSAR, DIST. BHARUCH

Terms of delivery: FOR PI JAMBUSAR SITE  
 Terms of payment: 100% WITHIN 30 DAYS FROM DATE OF DESPATCH  
 All documents should quote the Purchase Order number & the rate in Invoice should as per the Purchase Order. Test Report, Tax Invoice, Tram Card & MSDS (wherever applicable), should accompany the consignment.

Sr	Mat.Description Mat.Code GST No	Order Qty. UoM HSN/SAC Code	Price Tax Desc	Net Value
10	VALVE BALL SS316 2 PIECE FE 1 1/2"(T&G) 94020563 24AABCP2183M2ZA Deliv. date Day 11.12.2020	7 Number 84818010	SEZ: A/P: I GST) - 18% (CV)	
ALL THE VALVES ARE REQUIRED IN 150# AND WITH LIP SEAL DESIGN AND MATCHING FLANGES				
20	VALVE BALL SS316 2 PIECE FE 1 1/2"(T&G) 94020563 24AABCP2183M2ZA Deliv. date Day 11.12.2020	22 Number 84818010	SEZ: A/P: I GST) - 18% (CV)	
ALL THE VALVES ARE REQUIRED IN 150# AND WITH LIP SEAL DESIGN AND MATCHING FLANGES				

Total net value excl. tax INR 4,263,638.00

<p>NOTE:-</p> <ol style="list-style-type: none"> <li>Kindly acknowledge receipt of this document per return fax/mail.</li> <li>This is a SAP generated document and does not require signature.</li> <li>This document should be executed in Conjunction with Delivery Schedule only.</li> <li>Please refer the General Terms &amp; conditions of Supply.</li> </ol>	<p style="text-align: center;">Order Acceptance</p> <p>We accept this document/terms &amp; conditions</p> <p style="text-align: center;">(Authorized Signatory)</p>
--	---



PHBB VALVES PVT. LTD.  
 PCNTDA, PLOT NO. 238-239, SECTOR 10  
 BHOSARI  
 MIDC  
 PUNE 411026  
 BILLING STATE : MAHARASHTRA INDIA  
 SUPPLIER CODE : 3025293  
 GSTIN NO : 27AAHCP0913H1ZK

Purchase Order Type  
 Purchase Order No.  
 Date  
 Contact Person  
 Telephone Number  
 Pidilite Ind. Ltd. PAN No.  
 ZCAP-CAPITAL PO  
 1900037852  
 11.10.2019  
 PROJECTS 01  
 AAACP4156B

No.	Item Code	Item Description	UoM	Quantity	Rate(INR)	Value(INR)
10	N000000003	SS BALL VALVE,SIZE-(NB) 15 # 150	EA	2.000	00	
HSN/ SAC Code		8883	IGST		18 %	
I/O No :-		A0661801	Total ₹			

Delivery Date 08.11.2019 Quantity 2.000  
 HSN CODE : 84818030  
 TAG NO. VB-SS1-1, LINE SPEC-A2F, WETTED PART MOC SS, SIZE (NB) 15 RATING #-150

20	N000000003	SS BALL VALVE,SIZE-(NB) 25 # 150	EA	24.000		
HSN/ SAC Code		8883	IGST		18 %	
I/O No :-		A0661801	Total ₹			

Delivery Date 08.11.2019 Quantity 24.000  
 HSN CODE : 84818030  
 TAG NO. VB-SS1-1, LINE SPEC-A2F, WETTED PART MOC SS, SIZE (NB) 25 RATING #-150

Grand Total ₹ 507,451.92

Reference : R KHUMSE

Bill To / Ship To

PO Expiry Date :  
 Delivery Terms :  
 Payment Term : Due Immediate - 0 days  
 Time for delivery at Plant : 09:00 To 15:30

VAPI- 78/79 UNIT  
 77/II, 78/79  
 E ROAD, GIDC INDUS.ESTATE,  
 VAPI DIST.VALSAD  
 J TVJ TYPE, E-ROAD, VAPI, GUJARAT  
 VAPI 396195  
 GUJARAT INDIA

GSTIN NO : 24AAACP4156B1ZY

"The terms & conditions as per Annexure shall be applicable & will form an integral part of this order"



## PURCHASE ORDER

FOR/PUR/006

## TAGROS CHEMICALS INDIA LTD

"JHAVER CENTER", Rajah Annamalai Building,  
1Vth Floor, No.72, Marshalls Road, Egmore, Chennai-600008.  
Phone: 044-42007400. Fax: 044-28517164.

Factory: Plot No. 43/I, Amod Road, GIDC, Dahej-1,  
Tal-Vagra, Dist. Bharuch, Gujarat-393130.

VAT TIN No : 24211002684  
C.S.T No. : 24711002684  
C. Ex. Reg. No : AAAC2952KEM006  
ECC No : AAAC2952KEM006  
Range : IV & SERVICE TAX UNIT IV (DAHEJ)  
Division : BHARUCH  
Collectorate : VADODARA - II  
CIN No. : U24294TN1992PLC024115

P.O No.	P.O Date	Mode of Despatch	Payment Terms	Terms of Delivery
4500033787	16.02.2015	Any Reliable transport		FOB door delivery - Dahej

Vendor Contact Person Order	13254 <b>Mr.Hrishikesh Vanarase/0955250645</b> <b>PJV Valves Pvt Ltd</b> PLOT NO. 238-239, SECTOR 10, PCNTDA, BHOSARI, PUNE - 411026., Maharashtra Ph:020 6999 6017 Fax No: E-Mail:hvanarase@pjjvalves.com	1 Rate as per your Quotation No.MEPL/14-15/Q/2192 dt.09.02.15 & Subsequent discussion we had with you. 2 Indent no.400000054 & Project Code:91PEDIAUTO Dahej Phase-II 3 Other Contact Person: Mr.Hrishikesh Vanarase-09552510645,h.vanarase@pjjvalves.com Mr.Rahul Agrawal@09623716310, Email:r.agrawal@pjjvalves.com
-----------------------------------	--	---

M.Code	Material Description	UOM	Qty	Rate	Amount	Delivery Dt.
758319	SS316L BALL VALVE F/E300#15BarG300#C-25NB	No	4.000	INR		10.04.2015
758320	SS316L BALL VALVE F/E300#15BarG300#C-40NB	No	4.000	INR		10.04.2015
758321	SS316L BALL VALVE F/E300#15BarG300#C-50NB	No	8.000	INR		10.04.2015
758322	SS316L BALL VALVE F/E300#15BarG300#C-80NB	No	10.000	INR		10.04.2015
758323	SS316L BALL VALVE F/E300#15BarG300#C100NB	No	20.000	INR		10.04.2015
758325	SS316L BALL VALVE F/E600#40BarG300#C-25NB	No	4.000	INR		10.04.2015
758326	SS316L BALL VALVE F/E600#40BarG300#C-40NB	No	4.000	INR		10.04.2015
758327	SS316L BALL VALVE F/E600#40BarG300#C-50NB	No	8.000	INR		10.04.2015
758328	SS316L BALL VALVE F/E600#40BarG300#C-80NB	No	10.000	INR		10.04.2015
758329	SS316L BALL VALVE F/E600#40BarG300#C100NB	No	20.000	INR		10.04.2015
Note: 1. Refer our attached Annexure for detailed specifications & other Terms & Conditions. 2. For Floating Ball Valves each 2 Pair of seal are to be provided.						
					Less Discount:	0.00
<b>Sub Total</b>						<b>5765540.00</b>

Excise Duty 12.36% 712620.73  
Sales Tax/VAT 4% 259126.44  
Sales Tax/VAT 64781.61  
P & F 0.00

FOR TAGROS CHEMICALS INDIA LTD

PURCHASE MANAGER / AUTHORISED SIGNATORY



ORDER TYPE	ORDER NUMBER	ORDER DATE
Purchase Order	SBU - O & G (OIL, GAS & HYDROCARBONS)/KG DWN 98 2 PROJECT/500049/8297	21-FEB-2020

Vendor Name	PHBB VALVES PRIVATE LIMITED		
Vendor Address	SECTOR 10 PCNTDA BHOSARI Pune Maharashtra 411026 India		
Vendor Contact Details-1	Nagarajan, Mr.T.A.Nagaraja tanagarajan@phbbvalves.com 9820025082	Vendor Contact Details-2	Nagarajan, Mr.T.A.Nagaraja tanagarajan@phbbvalves.com 09820025082
Vendor PAN Number	AAHCP0913H	Vendor MSMED Registration Number	MH26B0018541
Vendor GSTIN Number	27AAHCP0913H1ZK	Buyer Company GSTIN Number	37AAACT4119L1Z7

Buyer's Contact Details	Mr. Dhanasekar A dhanasekar@tataprojects.com		
Order Annexures	Annexure 1	Schedule of Quantity, Item and Price	20 Pages Integrated Part of this document
	Annexure 2	Specific Conditions of Contract (SCC)	
	Annexure 3	Payment Terms	
	Annexure 4	Shipment Instructions	
	Annexure 5	Special Conditions of Contract (SCC) dtd. 10.02.2020	6 Page(s)
	Annexure 6	GPC for Supply : TPL/SCM/GPC/C2-HV R2 dtd. 13.12.2013	25 Page(s)
	Annexure 7	MR no-KG98/2-ONT-ME-GEN-MIS-00003 Rev-A dtd. 16-May-19	27 Page(s)
	Annexure 8	CPBG Format	2 Page(s)



Dear Sir/Madam,

Subject: PURCHASE ORDER FOR SUPPLY OF BALL VALVES ( LOT-3) FOR OGT & U-FIELD OF ONGC-KAKINADA PROJECT.

Reference:

- 1) Material Requisition (MR) no-KG98/2-ONT-ME-GEN-MIS-00003 Rev-A dated 16-May-19.
- 2) Final commercial offer ref: PHBB-D-529-11-19 REV 02 submitted vide email dated: 10-Feb-2020.
- 3) Special Conditions of Contract (SCC) dtd: 10-Feb-2020.

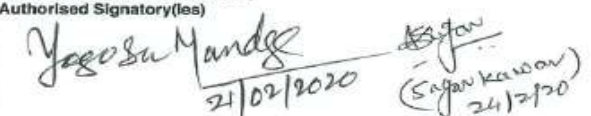
With reference to the above, we are pleased to issue this Order for the subject requirement as per the documents enclosed herewith as Annexures and the terms and conditions as detailed below. The technical specification sent along with the RFO, Subsequent clarifications, MOMs(if any) and all other terms and conditions (except otherwise specifically agreed to in writing) as specified here under and to be read along with attached annexures shall form an integral part of this Order

Total Contract Price Excluding Taxes	INR 3,15,46,024.00
Amount in words	(INR - Indian Rupee) Three Crore Fifteen Lakh Forty-Six Thousand Twenty-Four Only.
For TATA PROJECTS LIMITED, Authorised Signatory(ies)	
 21/02/2020 (Sanjay Kawar) 24/2/20	
	



## TATA PROJECTS LIMITED

One Boulevard 2nd 3rd &amp; 4th Floor Lake Boulevard Street Powai Mumbai 400 076

Tel + 91 22 6740 2900 Fax + 91 22 2570 0174

e-mail tpmumbai@tataprojects.com www.tataprojects.com

Registered Office Mithona Towers -1 1-7-80 to 87 Prenderghast Road Secunderabad 500 003 Telangana India

Tel + 91 40 6623 8801 Fax + 91 40 6617 2535 e-mail tpl@tataprojects.com www.tataprojects.com CIN U45203TG1979PLC057431



# Multimode Equipments Pvt. Ltd.

Regd. Office: 301-302 Rajvee Towers, Near Tube Company,  
Old Padra Road, Vadodara - 390 020, Gujarat, India.  
Tel: +91 265 2344512, 2323466, 2334977  
Email: multimode@gmail.com

Purchase Order No.: MEPL/18-19/326/R1  
Date : 21.12.2018  
GSTIN : 24AABCM4237B1Z2  
PAN : AABCM4237B  
CIN : U29224GJ1987PTC009745

## PURCHASE ORDER

Name : M/s. PJV VALVES PRIVATE LIMITED  
Address: Plot No. 238-239, sector 10  
PCNTDA, MIDC Bhosari,  
PUNE - 411 026. MAHARASHTRA.  
GSTIN: 27AAHCP0913H1ZK  
City Pin 411026  
State MAHARASHTRA  
Attn.: Mr. Rahul Agrawal / Mr. Kirti Bhutkar - Sales Engineer

**Our billing and consignee address**  
Name M/s. MULTIMODE EQUIPMENTS PVT. LTD.  
Address 301-302 Rajvee Towers, Nr. Tube Co.,  
Old Padra Road, VADODARA - 390020  
GSTIN: 24AABCM4237B1Z2  
City Vadodara 390 020  
State Gujarat 0265-2344512  
Yr Ref:Yr. Offer No. PVPL-D-535-11-18 Rev00 dtd 15-11-18

Sr. No.	Description	Qty (Nos)	Unit Price Rs.	Unit	Total Rs.
1	<p>PJV make Trunnion ball valve, side entry, split body M.O.C.</p> <p>Type of Valve : Trunnion ball valve, side entry, split body construction Construction : side entry, split body construction</p> <p>Bore : FULL Rating : Class 600# Ends : RF Body : WCB Ball : CF8M or SS316 Seats : SS316 + RPTFE Stem : SS 316 Seals : Viton + Graphite Bolting : B8M/BM Operator : GEAR OPERATED Size : 6" (150 mm)</p> <p><b>NOTES:</b> All Valve Specifications as per your Offer No. PVPL-D-535-11-18 Rev00 dtd 15-11-2018 and enclosed GAD No. PVPL-D-535-11-18-01 1). Valves are of fire safe design, with antistatic device and blow out proof stem 2). Painting : Shot blasting + 2 coat epoxy painted This valve is to be used at Calm Energy India Private Limited (Hazira) TEST CUM WARRANTEE CERTIFICATE REQUIRED ALONG WITH SUPPLY. However, Please send Scanned Copies prior to Dispatch.</p>	1		Nos.	-
	Sub Total:	1			

W O E 1300007



Oilfield Supplies FZCO  
P. O. Box 59893, Office No. 2801,  
28th Floor, Aspet Tower, Business Bay,  
Dubai, United Arab Emirates.  
Tel: +971-4-4436244, Fax: +971-4-4436523  
sales@ofsmc.com

## Purchase Order

PROJECT ENGINEERED VALVES PVT. LTD.  
Plot 238-239, Sector 10, PCNTDA  
(Bhosari, Pune - 411026, INDIA)

PO # OES/PO-751-09/2013  
This PO # and Our Job Card No.  
will appear on all correspondence.  
Terms & Billing conditions:  
Contract No. C-941/2013  
Date 19-Sep-2013  
Job Card No. JC-00185/2013  
Payment 30% Advance +40%  
PO and Balance 30 Days from date of delivery  
Requested By 24-Oct-2013

Tel: 0091 2027440000  
Fax: 0091 2027440000

Attn: Harshikesh  
Your Quotation (Mail, Dated : 04/7/2013)

Sl#	Description	Size	Part No.	Qty	Unit	Unit Price USD	Amount USD
1	<p>Floating ball Valve 4QJ 300# Reduced Bore, RF, Split body construction Body and Adapter : ASTM A 995 4A Ball : ASTM A 494 Carbon Stem : In. S25 Seat : RPTFE Bolting : B8M/BM Seals : Viton + Gr. Operator : Lever Mfg. OPEFA</p>			80	each	1,441.00	115,280.00
2	<p>Floating ball Valve 2X1-12" 150# Reduced Bore, RF, Split body construction Body and Adapter : ASTM A 216 WCB Ball : CF8M/SS316 Stem : SS316 Seat : RPTFE Bolting : B702H Seals : Viton + Gr. Operator : Lever Mfg. OPEFA</p>			20	each	85.00	1,700.00
<p>Note : Fire Safe Test to be conducted presence of our representative and Certificate to be issued in OPEFA name</p>							
Total FOB, Mumbai, India							116,980.00

(In Words : USD One Hundred Sixteen Thousand Nine Hundred Eighty Only)

Delivery : FOB, Mumbai  
Contact Person : Mr. Yousif (+971-55-1016248)

Prepared By  
*Rajesh*

Signature  
Sales - Technical  
*[Signature]*

Signature  
Business Development Manager  
*[Signature]*

Accepted by



WOODFIELD

**WOODFIELD SYSTEMS INTERNATIONAL PVT. LTD.**

Head Office : 302-A, Nites Biz Park, Plot No. C-19, Road No. 18, Wagla Estate, Thane (W) -400604 Maharashtra  
Ph: 0091-22-67040000 Fax: 0091-22-67040099 Email: sales@woodfieldsystems.com

Works : Plot No. 10, 11, Shivshakti Lghu Udyog Sankul, Mumbai-Nasik Highway, Village-Aeangan, Taluka-Shahapur,  
Dist-Thane-421 601 Maharashtra, India  
Tel Ph: +91-22-9223656300 Fax: Email: sales@woodfieldsystems.com

**PURCHASE ORDER**

PJV VALVES PVT LTD  
PLOT NO: 238-239  
SECTOR-10, PCNTDA  
BHOSARI  
Maharashtra 411026

PO Ref No. : WSIL/PJV/10728/7221 Date : 15-Nov-2016  
Kind Attn. : MR SURESH Direct No. : 9823395483  
Tel No. : Fax No. :  
Amendment Note :

We are pleased to place the order for following.

Sr No.	Description	Unit Rate (₹)	Quantity	Extended Rate(₹)
1	JACKETED BALL VALVE 4" X 6" FLANGED 150# WCB End Connection : 150# Flange End Ball Valve MOC : ASTM A216 GR WCB Jacket : A516 Gr.70 Or Equivalent Ball: SS304 Operation : Handle Operated 3/4" NPT(F) Steam in & Out Connection Ball Valve Shall Be CE Marked Service: Liquid Sulphur for Core & Steam for Jacket Design Temperature(Core): 270 Deg.C Design Pressure (Core): 5 Bar Design Temperature(Jacket): 270 Deg.C Design Pressure (Jacket): 6 Bar NOTE : YOUR QUOTATION REF NO : PJV-D-197-11-16 REV 00 Dtd 15.11.2016	90,000.00	1 Nos.	90,000.00
<b>TOTAL VALUE</b>				<b>90,000.00</b>
<b>Grand Total(₹)</b>				<b>90,000.00</b>

**TERMS AND CONDITIONS**

PRICE BASIS : EX-OUR WORKS ASANGAON  
FREIGHT : INCLUDED IN THE ABOVE COST  
DELIVERY : 100% WITHIN 6 WEEKS FROM THE DATE OF PURCHASE ORDER  
TAXES : EXCISE EXTRA AS APPLICABLE & VAT EXTRA AT ACTUALS TO OUR ACCOUNT  
PAYMENT TERMS : 100% WITHIN 30 DAYS OF RECEIPT OF MATERIAL AND DOCUMENTATION  
NOTE : 1)OUR PURCHASE ORDER NUMBER HAS TO BE MENTIONED IN INVOICE FOR PAYMENT PROCESS.  
2)ORDER ACCEPTANCE TO BE GIVEN AFTER RECEIPT OF ORDER .  
3)ALL DISPUTE SUBJECT TO MUMBAI JURISDICTION.

**ILJ CONSULTANTS**

1 JUNIPER CLOSE  
HOLLINGWOOD  
CHESTERFIELD  
DERBYSHIRE S43 2HX

**PURCHASE ORDER 001**

Date: April 4, 2017

Supplier **PJV Valves Private Limited**  
Contact: **Shamil Memolize**  
Plot 238-239 Sector 10  
PCNTDA Bhosari  
Pune- 411026  
India  
Tel: +91 2020 6999 6017

Your Quotation Ref:  
PJV-S-033-03-17 REV 00  
dtd 24-03-2017

Shipping Method	Shipping Terms	Delivery Date
Ex Works	Ex Works	24/05/2017

Item	Qty	Description	Unit Price	Line Total
1	2	10" ANSI 150# Double Offset Butterfly Valve Lugged and Through Drilled Body Material : ASTM A352 Grade LCC Disc Material : ASTM A351 Grade CF8M Seat: RPTFE+Inconel Backup Ring (Fire-safe Design) Shaft:SS316 Bolting: A320/L7/A194 7 S3 (hot Dipped Galvanized) Operation: Gear Operated NDT: Body 100% MPI Disc 100% DPI Radiography 1 off body 1 off disc 100% of critical areas as defined in ANSI B16.34 Materials supplied to NACE MR0175 CE Marking Anti Blow out and Anti Static Design Body Test @ 30Barg Seat Test @ 22Barg Gas Seat Test @ 6 Barg (Air) 3.1b material certificates required (Mill certificates) for the Body Disc Shaft and Bolting GA Drawings Deliver 8-10 weeks Ex Works ( Packed in sea worth crates)		

Registered Address: 21 Beeley Close, Inkensall, Chesterfield, Derbyshire S43 2HX  
Company No: 09931366



### PURCHASE ORDER

20-0500475-W

PJV VALVES PRIVATE LIMITED - (P1341)

PLOT 238-239, SECTOR K10,  
 PCNTDA BHOSARI, PUNE-411026,  
 INDIA

Attention : MS KIRTI BHUTKAR  
 Tel : 91(0)20 6999 6017  
 Fax :

Date : 17/08/2017  
 Your Ref : 14009043  
 Our Ref :  
 S/O # : SOPD14002484  
 Currency : US DOLLARS  
 Marking : JAS/B-CAT/08/17  
 Delivery Date : 10 WEEKS

No.	Item Code	Description	Quantity	Price (USD)	Amount (USD)
-----	-----------	-------------	----------	-------------	--------------

Department : (70A) GENERAL

1.00	ZZ	FLOATING BALL VALVE, SS 316 / F316	2.00 PCS	463.00	926.00
------	----	------------------------------------	----------	--------	--------

CONSTRUCTION : V-NOTCH, 30DEG  
 SIZE : 2"  
 BORE : V-PORT  
 RATING : 150#  
 ENDS : RF  
 SEATS : RPTFE  
 STEM : SS 316  
 BOLTING : B7M/2HM + HDG  
 SEALS : VITON + GR  
 OPERATOR : LEVERT  
 BODY : WCB

2.00	ZZ	CERTIFICATIONS & DOCUMENTATION	1.00 LOT	90.00	90.00
------	----	--------------------------------	----------	-------	-------

3.00	ZZ	PAINTING	1.00 LOT	595.00	595.00
------	----	----------	----------	--------	--------

4.00	ZZ	EXPORT PACKING	1.00 LOT	85.00	85.00
------	----	----------------	----------	-------	-------

Sub Total (USD) : 1,696.00

Less Discount (USD) : 0.00

Total (USD) : 1,696.00

Add : 0.00% GST (USD) : 0.00

Total Amount (USD) : 1,696.00



VME PROCESS ASIA PACIFIC PTE LTD

Phone: +65 6872 9246 / Fax: +65 6491 5903

PURCHASE ORDER

AP170359-0001 Rev 00

SUPPLIER	INFORMATION
<b>PJV VALVES PRIVATE LIMITED</b> PLOT 238-239, SECTOR 10, PCNTDA, BHOSARI PUNE 411206 India Contact:	P.O. Number: AP170359-0001 Rev 00 Order Date: 9/21/2017 Currency: US Dollar Supplier ID: 501640 Payment Terms: Due before Shipment Delivery Terms: EX WORKS PUNE INDIA Buyer: KCLEE Your Quote Ref: PJV-E-100-08-17 REV 00 Shipping Method: AIR FREIGHT Terms & Conditions: VME general purchase terms & cond (Rev 5/2017) shall apply
SHIP TO ADDRESS	
Ship spares in transit for "Yinson Genesis" Keppel shipyard limited (Tuas) Blue Store 51 Pioneer sector 1 Singapore 628437 Attn: Chen(91557738)	
INVOICING ADDRESS	
<b>VME PROCESS ASIA PACIFIC PTE LTD</b> 3 SCIENCE PARK DRIVE, THE FRANKLIN SINGAPORE SCIENCE PARK 1, #02-08/09 SINGAPORE, 118223 SINGAPORE email: VMEAPaccounts payable@vmeprocess.com	

LN.	PART NO. / DESCRIPTION	QTY	UM	UNIT COST	TOTAL
1	Part/Material Specs: FLOATING BALL VALVE 4" RB 600LB RTJ WCB BODY 6MM CA SIDE ENTRY, F316 BALL + ENP RPTFE SEAT INSERT, SS316+ENP STEM VITON AED+Gr SEALS, B7M/2HM+HDG BOLTING GEAR OPERATED  Valve tag : - 26BAV2349 Valve Spec : VB 515 AG 1C 8  Quote Ref : PJV-E-100-08-17 REV 00 Revision: 00 Ship Date: 10/5/2017	1.00	EA		
	Deliver on: 10/5/2017				

TOTAL ORDER VALUE:

### PURCHASE ORDER REQUIREMENTS

Notes:

- 1) All valves are with anti blow out stem and with antistatic device
- 2) Design & Manufacturing standard for ball valves : ASME B 16.34, ASME B 16.5, ASME B 16.10, ISO 17292, API 6D
- 3) Pressure testing standard : API 598, API 6D





PURCHASE ORDER

BRIDGESTONE INDIA PRIVATE LIMITED

Plot No. A-43, Phase-II, MIDC Chakan, Village Sawantari, Taluka Khed, Dist. Pune, Maharashtra - 410 501, India. CIN: U28111PN1205PTC147267 Tel: +91-2135-873-000, Fax: +91-2135-871-000 Website: www.bridgestone.co.in

P.O. NO. Page No. 1 PE77427 21/07/2017

BUYER: ANIKET ASHOK SHETYE OUR REF NO. DT. YOUR REF NO. DT.

1. Please supply the following goods / services as per the terms & conditions mentioned. 2. Please mention our purchase order no. & item code on your Order & Invoice. 3. Documentary proof of order sold should accompany the material. 4. Communicate your acceptance within 7 days. 5. Please raise separate Invoice / Check for each Purchase Order.

PJV Valves Pvt Ltd Plot No. 238-239, S No. 10, PCNTDA, Bhosari, Pune Pune MH 411026 GSTIN: 27AAHCP0913H1ZK Bridgestone India Private Ltd Plot No. A-43, Chakan Ind. Area Phase-II, Tal. Khed, Dist. Pune Pune (MS) 410501 GSTIN: 27AABCB2304E1ZD TIN: 27110000678V CEST: 27110000679C SER. TAX REGN. NO.: AABCB2304E50000 EDD NO.: AABCB2304E5M003 RANGE: CHAKAN DIV.: PUNE - V COMMISSIONERATE: PUNE - 1 PAN NO: AABCB2304E

Table with 7 columns: SR. NO., ITEM CODE & DESCRIPTION, UOM, QUANTITY, UNIT RATE RS., DISCOUNT, AMOUNT INR. Rows include AUTOVALVEASSEMBLY, AUTOVALVE ASSEMBLY, AUTOVALVE ASSEMBLY.

P & F: EXCISE DUTY FREIGHT: F. O. R. Site SALES TAX: 9.00%/ 18695.83 OTHER: NIL SGST @ 5%

GRAND TOTAL (IN WORDS) RUPEES TWO LAKH FORTY FIVE THOUSAND AND ONE HUNDRED TWENTY THREE AND 53 GRAND TOTAL 245123.16

PRICE BASIS: F.O.R SITE PAYMENT TERMS: 30 Days Credit

DELIVERY DATE: 21/08/2017 (SN/BCD/CQ)

REMARKS: .Continued



GUJARAT FLUOROCHEMICALS LIMITED



Tel. : (02641) 618641-47/59 Fax : (02641) 618612

12/A, GIDC Dahaj Industrial Estate, Tal. Vagra, Dist. Bharuch - 392130, Gujarat, India.

Draft Purchase Order

Table with 4 columns: Vendor's Name & Address, Code, P.O. No., Date, Your Reference, Our Reference, Price Basis, Payment Terms, Page.

Please supply following in accordance with instructions given below & subject to standard conditions mentioned overleaf.

Main table with 5 columns: Sr No., Material No. / Description, Quantity, Unit, Price / Unit, Net Value(INR). Rows include BUTTERFLY VALVE CS 350NB WAFER TYPE 150# VU3172 and BUTTERFLY VALVE CARBON STEEL 350NB WAFER TYPE 150# VU3172.







ANB Sp. z o.o.  
ul. Zerzeńska 36  
04 – 787 Warszawa

tel.: 22 612 16 16  
fax: 22 612 29 30

biuro@anb.com.pl  
[www.anb.com.pl](http://www.anb.com.pl)

Date : 04/07/2017

TO WHOMSOEVER IT MAY CONCERN

This is to confirm that M/s PJV Valves Pvt.Ltd.( CIN: U29244PN2013PTC146838 ) based at Plot 238-239, Sector 10, PCNTDA, Bhosari, Pune – 411026, INDIA had supplied automated floating ball valves (1" to 3" FB 600# in Carbon Steel) against our PO No 13-188 in Feb 2014. The valves have been performing satisfactorily since then.

Włodzimierz Klasa  
*Włodzimierz Klasa*  
DYREKTOR

ANB Sp. z o.o.  
ul. Zerzeńska 36  
04-787 Warszawa  
[www.anb.com.pl](http://www.anb.com.pl)  
tel. 22 612-16-16 fax 22 612-29-30



Channel Partner

Date : 06/03/2019

TO WHOMSOEVER IT MAY CONCERN

This is to confirm that M/s PJV Valves Pvt.Ltd.( CIN: U29244PN2013PTC146838 ) based at Plot 238-239, Sector 10, PCNTDA, Bhosari, Pune – 411026, INDIA had supplied 27 PCs of automated floating ball valves with positioners (1/2" & 1-1/2" in 150#, 300# & 3000 psi (1500#) in Stainless Steel -CF8M) of value USD 93,012 against our PO No 17-172 REV 02 dtd 28/08/2017. The full PO was completed & shipped in October 2017. The valves have been performing satisfactorily since then.

Włodzimierz Klasa  
*Włodzimierz Klasa*  
DYREKTOR

ANB Sp. z o.o.  
ul. Zerzeńska 36  
04-787 Warszawa  
[www.anb.com.pl](http://www.anb.com.pl)  
tel. 22 612-16-16 fax 22 612-29-30

Masoneilan

Consolidated

MARC

Austriacký Series, Motorized

Nil-Cor

MOGAS

CARRARO

dynadon SDD

REXROTH

FNC Tank Protection Design

Date : 02/10/2018

TO WHOMSOEVER IT MAY CONCERN

This is to confirm that M/s PJV Valves Pvt. Ltd.(CIN: U29244PN2013PTC146838 ) based at Plot 238-239, Sector 10, PCNTDA, Bhosari, Pune – 411026, INDIA had supplied floating ball valves from 1" to 8" with lip seals of rating 300# ( in Hast alloy C, Stainless steel for hydrogenation) against our various orders (6700000331, 6700000359, 6700000396, 6700000427, 6700000702, 6700000755, 6700001991) in June 2017 & July 2018. These valves have been installed in our plant & the same have been performing satisfactorily since then.

These valves were Fugitive Emission tested (FET with Helium) tested for 100% qty as per ISO 15848.

Authorised sign

Date : 04/08/2017

TO WHOMSOEVER IT MAY CONCERN

This is to confirm that M/s. PJV Valves Private Limited (CIN : U29244PN2013PTC146838), based at Plot 238-239, Sector 10, PCNTDA, Bhosari, Pune, India have supplied approximately 1400 pcs of Floating & Trunnion ball valves from sizes ½" to 20" & in pressure ratings from 150# to 2500# against our order AP1427-0056. The valves were supplied in April 2016 for our OCTP, Ghana project. The valves have been installed on the FPSO & the performance of the same is satisfactory.

For VME Process Asia Pacific Pte Ltd.

Name, Designation, Signature

G.Sachi

Package Engineer

VME Process Asia Pacific Pte. Ltd.





Orseal Ltd.  
Lynstock Way  
Lostock, Bolton  
Lancashire BL6 4QR

Tel: +44 (0)1204 474300  
Fax: +44 (0)1204 474347  
E-mail: [sales@orseal.com](mailto:sales@orseal.com)  
Website: [www.orseal.com](http://www.orseal.com)



the valve specialists

## REFERENCE LETTER

Date : 25/07/2017

TO WHOMSOEVER IT MAY CONCERN

This is to confirm that M/s PJV Valves Pvt.Ltd.( CIN: U29244PN2013PTC146838 ) based at Plot 238-239, Sector 10, PCNTDA, Bhosari, Pune – 411026, INDIA have supplied floating ball valves from ½" to 4" and of rating 150# ( in Carbon steel & Stainless steel) against our order (12544) in 2017. These valves have been supplied in 2017 & the same have been performing satisfactorily since then.

Kind regards  
**ORSEAL LTD.**

Mr. Shaun Gray  
Operations Director

**ORSEAL LIMITED**  
LYNSTOCK WAY  
LOSTOCK  
BOLTON  
BL6 4QR.



Directors: R. M. Akers, D. Crumpton, S. J. Dunbar, S. Biny, C. M. Fehle  
Registered No. 7078629 ENGLAND VAT No. 45 2067 62



**Tagros**  
(a jhaver group company)

Tagros Chemicals India Pvt. Ltd.  
Plot No.43/1, Amod Road,  
GIDC Dahaj 1, Taluka Vagra District  
Bharuch - 392 130, Gujarat, India  
Web : [www.tagros.com](http://www.tagros.com)  
CIN.No. U24210GJ1995PTC049211

27<sup>th</sup> July, 2017

## TO WHOMSOEVER IT MAY CONCERN

This is to certify that M/s. PJV Valves Private Limited, Bhosari, Pune has supplied 92 Nos. Ball valves of size range 25mm to 100mm in rating 300# and 600# in SS316L MOC vide our PO reference 4500033787 dated 16.2.2015 in tune of ₹ 5765540.

We are pleased to inform that valves supplied by PJV Valves Private Limited are working satisfactorily at our site till date and we are satisfied with the performance of the valves.

For Tagros Chemicals India Pvt Ltd

Authorized Signatory



Corporate Office ("Jhaver Centre" Rajah Anaram Building, IV Floor, 72, Maratha Road, Egmore,  
Chennai 600 008, Tamilnadu, India. Phone : 0991 - 44 - 42007400 Fax : 0991 - 44 - 28587571,28517154  
Web : [www.tagros.com](http://www.tagros.com)  
Works 1 : A-4/1,2 & 3 Spout Industrial Complex, Pachayankuppam, Gudalur - 607 000, Tamilnadu, India  
Phone : +91-04142 - 239373, 239374, Fax : +91 - 04142 - 239375



# PHBB Valves Private Limited

Plot No.238-239, Sector-10, PCNTDA,  
Bhosari, Pune, Maharashtra- 411026

Email : [Sales.phbb@gmail.com](mailto:Sales.phbb@gmail.com) / [sales@phbbvalves.com](mailto:sales@phbbvalves.com)

Mob: 9987094499

## # Network :

- Pune • Nashik • Mumbai • Vadodara • Delhi NCR • Kolkata
- Jamshedpur • Bhopal • Jaipur • Raipur



Thank  
you